HANDLEIDING
MOUNTING INSTRUCTIONS
INSTRUCTIONS DE MONTAGE
AUFBAUANLEITUNG
MONTAGE-VEJEDNING
MONTERINGSVEILEDNINGEN
ISTRUZIONI DI MONTAGGIO



Modern

PRODUKTINFORMATIE

Geachte klant,

U heeft met de aanschaf van deze aluminium serre een juiste keuze gemaakt waarmee wij u veel plezier wensen.

OPMERKINGEN

Deze handleiding is vooreerst opgesteld voor alle standaardconstructies maar bevat voldoende aanwijzingen om een vlotte montage van andere uitvoeringen te garanderen. De zwarte rubber strips zijn aan de binnenkant met olie behandeld, dit garandeert een eenvoudige en snelle montage. Deze serre heeft het kweken van planten en bloemen tot doel en wordt slechts betreden voor het gebruik door een hiervoor bevoegde persoon. Kleine ondiepteden en condensatiewater in deze constructies zijn dan ook toelaatbaar! Mogelijke zwarte plekken op de profielen zijn eenvoudig met een aluminiumreinigingsmiddel af te nemen, het betreft geen productiefouten. De serre dient geplaatst te worden op een voldoende draagkrachtige betonfundering die voorzien is tot op vaste vorstvrije grond. De verankering van de serre alsook het regelmatig controleren van de toestand dient steeds door de eigenaar of exploitant te worden voorzien. Het dak van de serre dient in de winter van sneeuw bevrijd te worden, of op een gepaste manier ondersteund worden. De serre moet op een van de wind afgeschermden plaat opgebouwd worden. Tijdens de montage dient men gepaste beschermende kledij te dragen (b.v. veiligheidshandschoenen) om kwetsuren te vermijden. Men dient steeds de lokaal gebruikelijke bouwverordeningen in acht te nemen.

VOLGORDE VAN DE MONTAGE

Opbouw en montagevolgorde is voor alle modellen hetzelfde.

- Uitsorteren van aluminium profielen volgens modelgrootte.
- Montage en opbouw van gehele constructie.
- Horizontaal en waterpas stellen van de constructie.
- Verankering van de constructie.
- Beglazing.

BENODIGD GEREEDSCHAP

Schroefsleutel Nr. 10, schroevendraaier, waterpas, boorapparaat en boortje Ø4.2, metaalzaag, werkhandschoenen, schaar (voor het snijden van rubber).

Constructiewijzigingen onder voorbehoud.

PRODUCT INFORMATION

Dear customer

Thank you for buying a high-quality aluminium greenhouse.

REMARKS

In all drawings you find the mounting-instructions for all basic standard-models. However this manual should be a sufficient guidance for all special-case greenhouses. This greenhouse is designed for cultivation of plants/flowers. Therefore leakage, water drops and condensation inside the building are allowed. The building may only be entered by competent persons during cultivation or maintenance. Aluminium profiles that are not painted may show black stains, these stains are not a production error: they can be easily removed with a aluminium cleaner available at every good drugstore. The rubber strips have been treated with oil/silicone on the interior to facilitate the assembly. The building should be mounted on a solid concrete foundation deep enough to get a solid and frost-free ground. Anchoring of the foundation should be made by the owner or operator and should be checked periodically. During winter the roof has to be cleared of snow or supported in a suitable way. The greenhouse should be built in a location protected from strong winds. Protective gear (such as protective gloves) should be used during mounting in order to avoid injuries. One should at all times pay attention to the local building regulations.

ASSEMBLY ORDER

The assembly procedure is the same for all our greenhouses.

- Sorting of the profiles according the model.
- Mounting of the complete aluminium construction.
- Leveling of the construction using a waterlevel.
- Securing the building to the ground
- Glazing.

REQUIRED TOOLS

Socket wrench nr. 10 or spanner nr. 10, water-level, screwdriver, drilling machine + drill 4.2 mm, scissors (to cut the rubber).

We reserve the right to change the construction without prior notice!

INFORMATION SUR LE PRODUIT

Cher client,

Nous vous félicitons à l'achat de la serre en aluminium.

REMARQUES

Dans ce manuel vous trouvez les instructions de montage pour tous les modèles standards. Par contre, ce manuel est aussi un bon guide pour tous les modèles spéciaux. La serre est une verrière pour cultiver des plantes et des légumes: des petites fuites et de l'eau de condensation sont autorisées.

Les couvercles noirs en caoutchouc sont, à l'intérieur, traités à l'huile. Ceci garantit un montage simple et rapide. Si les profilés en alu montrent des taches noires, il ne s'agit pas d'un défaut de production. Ces taches peuvent facilement être enlevées au moyen de nettoyeurs pour aluminium, qui sont disponible sur le marché. Une fondation à l'abri du gel et portance suffisante est nécessaire. Pendant l'hiver il faut enlever la neige de la toiture ou étançonner le toit. Il faut construire la serre dans un endroit protégé du vent. Afin d'éviter des blessures lors de la montage, il faut porter des vêtements de travail, qui pourront vous protéger (p.ex. des gants de sécurité). En tout cas il faut respecter les règles urbanistiques locales.

DÉROULEMENT DU MONTAGE

L'ordre de montage est identique pour tous les modèles :

- Triage des profilés en alu en fonction des dimensions du modèle.
- Assemblage des profilés et montage de la structure.
- Alignement vertical et horizontal de la construction.
- Pose du vitrage.

OUTILLAGE NÉCESSAIRE

Clef N° 10, tournevis, niveau à bulle, perceuse et foret Ø4.2mm, scie à métaux, gants de travail, ciseaux (pour la mise à longueur du joint en caoutchouc).

Sous réserve de tout changement.

PRODUKT INFORMATION

Sehr geehrter Kunde,

Wir möchten Ihnen zum Kauf dieses Gewächshauses gratulieren.

ANMERKUNGEN

Die Aufbauanleitung bezieht sich zunächst auf das Standardmodell. Für Sonderkonstruktionen gibt es zusätzliche Hinweise zur Montage. Das Gewächshaus sollte in einer windgeschützten Lage montiert werden. Während des Winters sollte das Dach von Schnee befreit werden oder durch geeignete Maßnahmen abgestützt werden! Alle Konstruktionen sind bauseits in geeigneter Weise am Aufstellungsort zu verankern! In jedem Fall muss ein frostfreies Betonfundament vorhanden sein. Das Gewächshaus ist vom Betreiber regelmäßig auf ihren ordnungsgemäßen Zustand zu untersuchen.

Unlackierte Alu-Profile können schwarze Flecken aufweisen, hierbei handelt es sich nicht um einen Produktionsfehler. Mit einem handelsüblichen Alu-Reiniger lassen sich diese weitestgehend entfernen. Die Gewächshäuser dienen der Kultur von Pflanzen und werden durch gärtnerische tätige oder entsprechend autorisierte Personen oder nur in deren Begleitung betreten. Kleine Undichtigkeiten, Wassertropfen und Kondensat sind zulässig. Das mitgelieferte Dichtungsgummi ist an der Innenseite mit Talg behandelt, was zu einer schnelleren und einfacheren Montage beiträgt. Bei der Montage muss man Schutzausrüstung tragen z.B. Sicherheitshandschuhe, um Verletzungen zu vermeiden. In jedem Fall muss die landesübliche Bauordnung beachtet werden!

MONTAGEABLAUF

Der Montagevorgang ist bei allen Modellen gleich:

- Auslegen der Alu-Profile gemäß Modellgröße.
- Aufbau der Alu-Konstruktion.
- Horizontale und vertikale Ausrichtung der Konstruktion.
- Verankerung der Konstruktion.
- Verglasung.

BENÖTIGTES WERKZEUG

Schraubenschlüssel Nr. 10, Schraubenzieher, Wasserwaage, Bohrmaschine und Bohrer (4.2 mm) Metallsäge, Schere (für das Zuschneiden der Gummidichtung).

Konstruktionsänderungen behalten wir uns vor.

PRODUKT-INFORMATION

Kære kunde,

Tillykke med Deres nye drivhus. De har valgt et højt kvalitetsprodukt, som De vil få megen fornøjelse af.

BEMÆRKNINGER:

Denne montage-vejledning er først og fremmest lavet for alle vores standardkonstruktioner, men kan også bruges til montage af specielkonstruktioner, da der er inkluderet flere supplerende anvisninger. Drivhusets funktion er at dyrke planter og blomster; små utætheder samt kondens er tilladt i disse konstruktioner. Drivhuset kan bedst placeres et beskyttet sted. Alle gummilister er indvendigt behandlet med olie, som sikrer en enkelt og hurtigt montage. (Pas på det kan smitte af på fliserne). På underkanten af tagrenden er der forudset en rille, hvor der IKKE skal monteres gummilister. Mulige sorte pletter på profilerne kan nemt fjernes med et aluminiums rengøringsmiddel – disse er ikke produktionsfejl. Drivhuset skal placeres på en bæredygtig undergrund, en terrasse eller et rigtig fundament. Taget skal holdes snefrit om vinteren, eller skal støttes på en passende måde. Husk at overholde de lokale byggeforskrifter.

FREM GANGSMÅDEN FOR MONTAGEN:

Oppbygning og montage er den samme for alle størrelser.

- Lægge alle dele frem
- Monter hele aluminiumskonstruktionen
- Sæt konstruktionen i vatter og i vinkel.
- Monter glasset

VÆRKTØJ:

Nøgle nr. 10, skruetrækker, vatterpas, boremaskine og bor \emptyset 4,2 mm, arbejdshandsker, saks (for at klippe gummilisterne)

Vi tar forbehold om endringer i konstruksjonen.

PRODUKTINFORMASJON

Kjære kunde

Til lykke med Deres nye drivhus. De har valgt ett høy-kvalitetsprodukt, som vi håper De vil få meget glede av.

BEMERKNINGER

Denne monteringsveiledningen er først og fremst laget for alle våre standardkonstruksjoner, men kan også brukes til montering av spesialkonstruksjoner, da det er inkludert flere supplerende anvisninger. Drivhusets funktion er at dyrke planter og blomster; små utætheder samt kondens er tilladt i disse konstruktioner. Drivhuset kan bedst placeres et beskyttet sted. Alle gummilistene er innvendig behandlet med olje, som sikrer en enkel og hurtig montering. (Vær obs på at oljen kan smitte av.) På underkanten av takrenden er det en rille hvor det IKKE skal monteres gummilister. Mulige sorte pletter på profilene kan lett fjernes med ett aluminiums rengjøringsmiddel – disse er ikke produksjonsfeil. Drivhuset skal placeres på en bæredygtig undergrund, en terrasse eller et rigtig fundament. Om vinteren bør taket gjøres fritt for snø. Drivhuset bør plasseres på et lunt sted. De bør bruke beskyttende tøy som for eksempel hansker ved montering. Husk at overholde de lokale byggeforskrifter.

FREM GANGSMÅTE VED MONTERING

Oppbygging og montering er den samme for alle størrelser.

- Legg alle deler frem.
- Monter hele aluminiumskonstruksjonen
- Sett konstruksjonen i vater og vinkel.
- Monter glassene / isolerplastplatene.

VERKTØY

Nøkkel nr. 10, skrutrekker, vater, boremaskin og bor \emptyset 4,2mm, metallsag, arbeidshansker, saks (for å klippe gummilistene).

Vi tar forbehold om endringer i konstruksjonen.

PRODUKTINFORMATION FÖR MONTAGE VÄXTHUS

Bästa kund.

Tack för att Ni köpt ett växthus av aluminium med hög kvalitet.

På de följande sidorna hittar ni monteringsanvisningar för de varierande modellerna samt skisser på de olika profilerna. För de hus som inte är lackerade (ren aluminium) kan det ibland finnas mörkare fläckar vilket är naturligt. Dessa kan med lätthet tvättas bort med en aluminiumrengörare som kan köpas i färghandeln. Gummiprofilerna har blivit behandlade med olja för att underlätta vid montering. Grundarbetet måste vara utfört på sådant sätt att marken inte rör sig vid tjäle samt att huset bör vara förankrat genom fastgjutning. Vid snöfall under vintern bör snön tas ned från taket. Vid rikligt snöfall bör huset gärna stöttas i mitten på nocken speciellt om Ni inte befinner Er på plats där under vinterhalvåret. Växthuset bör placeras på en skyddad del av trädgården där vinden är mindre stark. Vid montering av glaset bör handskar användas för att skydda mot skärskador. Följ de lokala lagar vad gäller bygglövs.

MONTERINGSFÖLJD

Monteringsföljden är den samma för alla växthusen.

- Sortera upp profilerna och placera dem i den ordning som de skall monteras.
- Montera ihop hela aluminiumkonstruktionen innan glasning.
- Kryssmät diagonalerna noggrant samt använd ett vattenpass innan glasningen.
- Glasning.

VERKTYG SOM BEHÖVS VID MONTERING

Fast nyckel nr. 10 eller hylsnyckel nr. 10, Vattenpass, Skruvmejsel, Sax (för klippning av gummilist), Borrmaskin och borr 4.2 mm samt 6.5 mm.

Vi förbehåller oss för rätten att ändra i konstruktionen utan att i förväg meddela sådant.

INFORMAZIONI GENERALI SUL PRODOTTO

Caro Cliente,

Ti ringraziamo per aver scelto una Serra in alluminio di "alta-qualità".

OSSERVAZIONI

Nei disegni sono specificate le istruzioni di montaggio per tutti i modelli standard. In ogni caso questo manuale risulta essere una guida più che sufficiente anche per l'installazione di Serre realizzate "su misura". I profili d'alluminio potrebbero presentare alcune macchie scure. Tali macchie non sono dovute ad errori di produzione e possono altresì essere rimosse usando comuni prodotti per la pulizia dell'alluminio, disponibili nelle migliori rivendite specializzate. Le guarnizioni in gomma sono trattate con olii speciali al fine di facilitarne l'applicazione. Il terreno sul quale viene posata la serra deve essere opportunamente isolato e predisposto per la realizzazione di una fondamenta in cemento. In inverno, è consigliabile rimuovere la neve dal tetto o supportare la Serra dall'interno. Consigliamo inoltre di installare la Serra in una zona riparata dal vento. Durante la fase di installazione è preferibile usare dispositivi ed attrezzatura di protezione personale (es.: guanti) allo scopo di evitare qualsiasi danno alle persone. Consigliamo vivamente di verificare le normative locali vigenti in merito alla realizzazione di strutture di questa tipologia.

FASI DI MONTAGGIO

La procedura di installazione è uguale per tutte le Serre.

- Verificare e disporre in ordine tutti i profili in alluminio che compongono la Serra.
- Montare completamente la struttura in alluminio.
- Livellare la struttura e controllarne lo squadro degli angoli e delle diagonali.
- Posizionare le lastre di tamponamento (vetro, policarbonato etc.).

ATTREZZATURA NECESSARIA PER IL

MONTAGGIO

Chiave inglese o chiave a bussola nr.10, livella ad acqua (bolla), cacciavite, trapano con punta \varnothing 4 mm, forbici (per tagliare la guarnizione).

Ci riserviamo il diritto di apportare eventuali modifiche del prodotto in qualsiasi momento e senza preavviso.



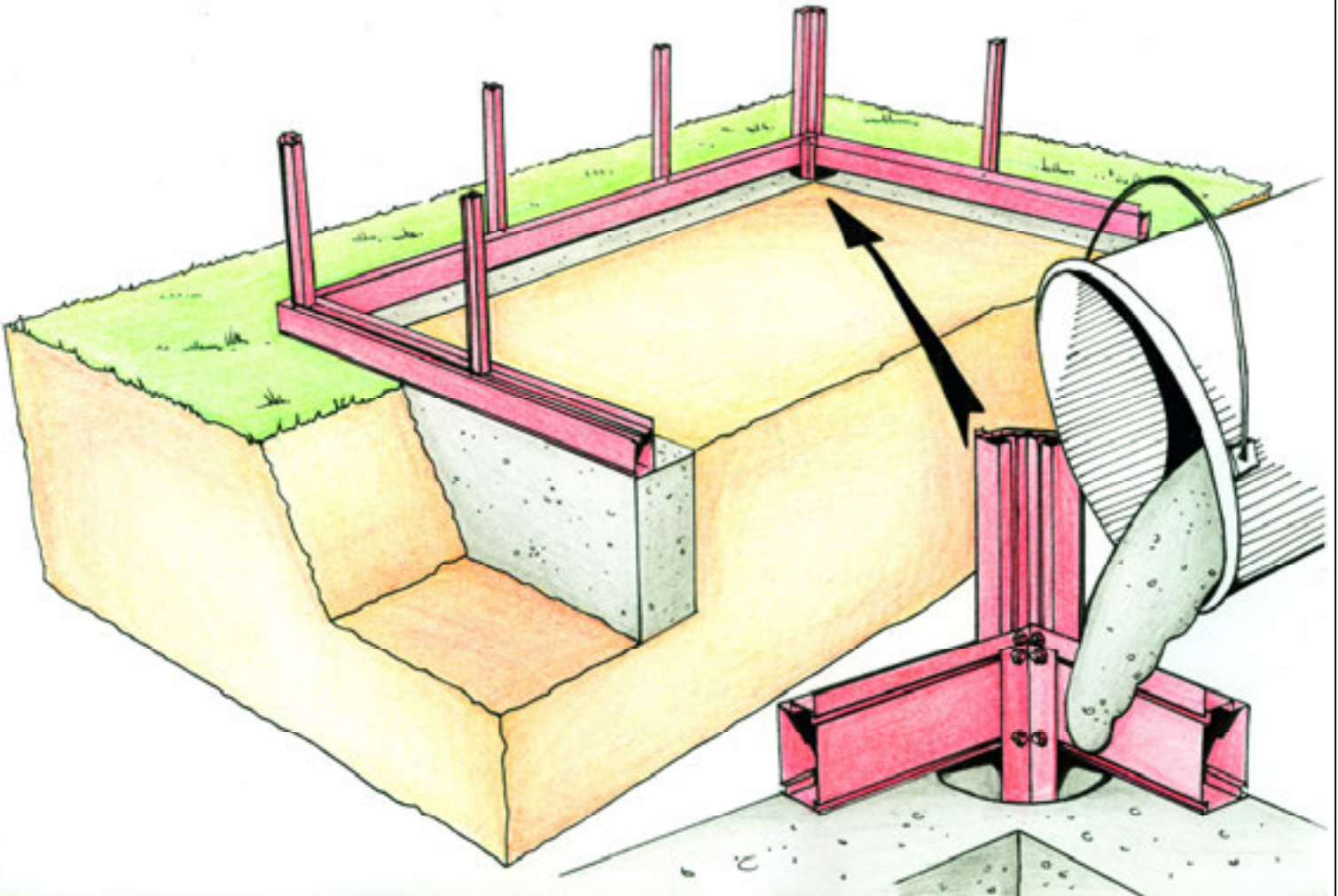
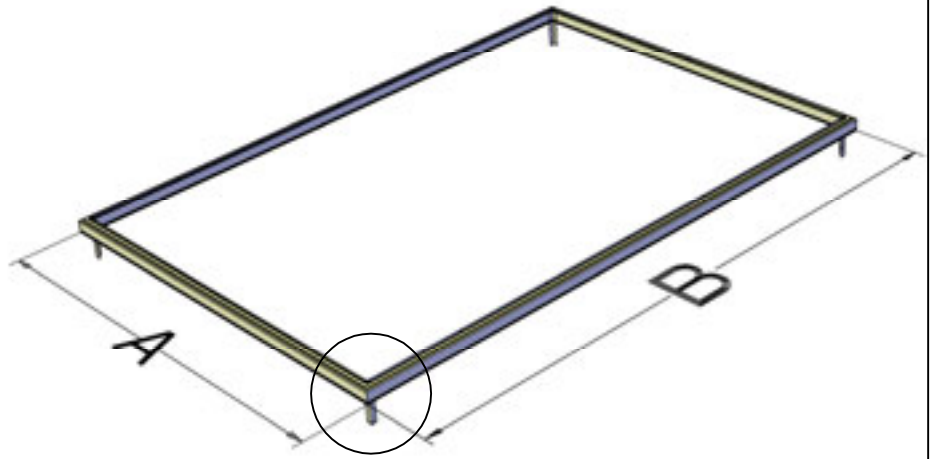

" MODERN "

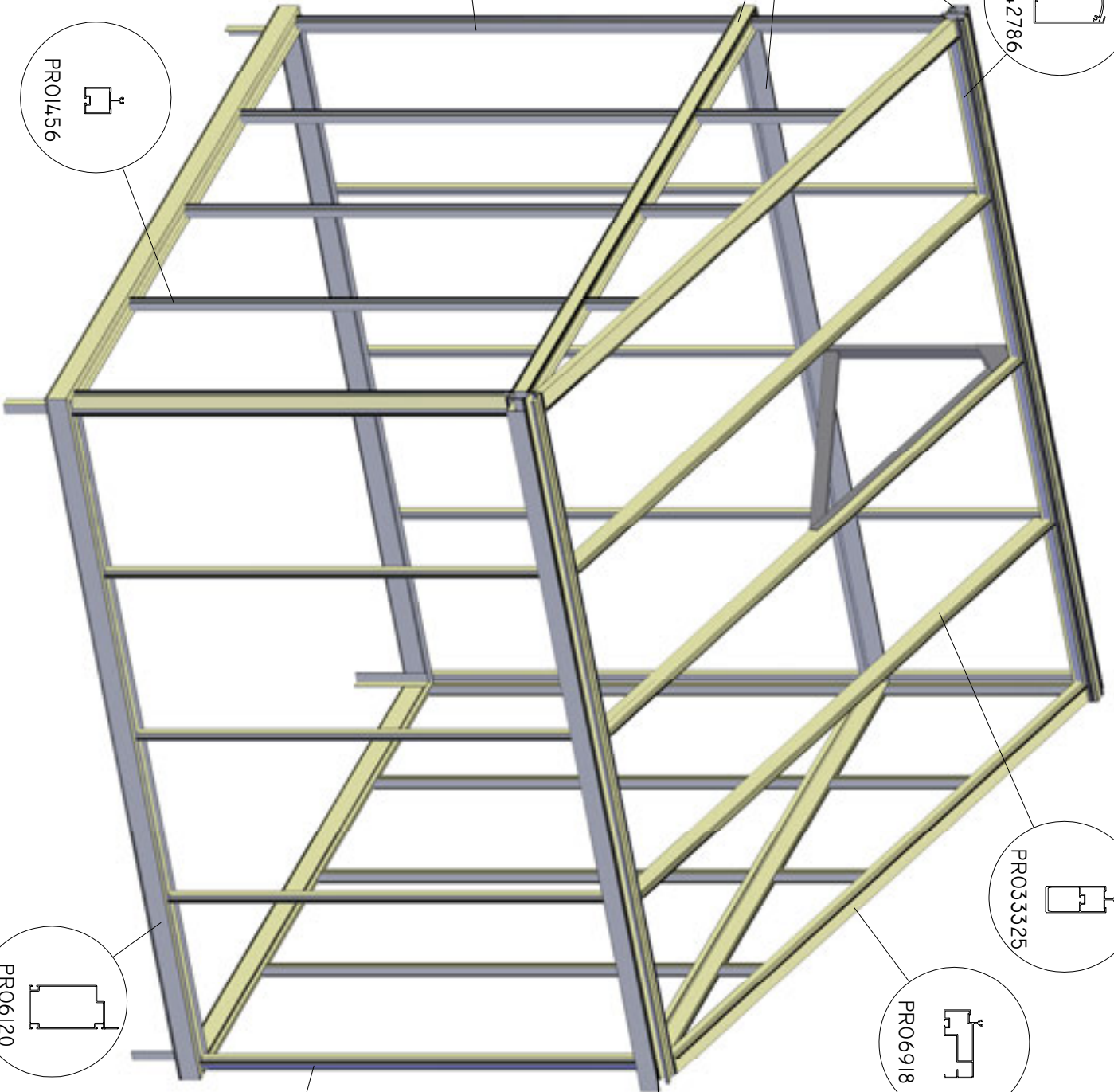
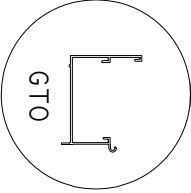
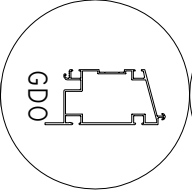
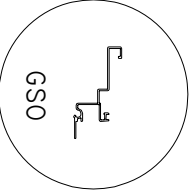
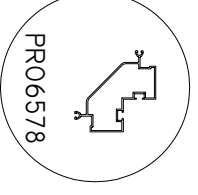
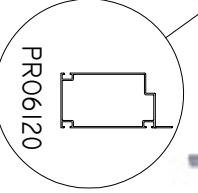
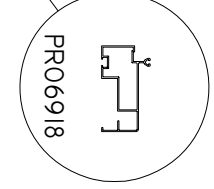
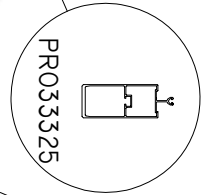
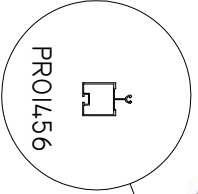
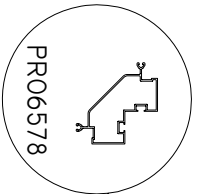
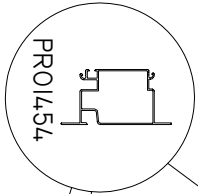
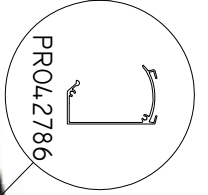
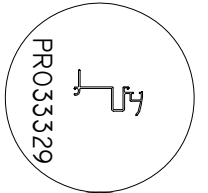
A	X	B
2.360mm		2.360mm
3.098mm		3.098mm
		3.836mm
		4.574mm
		5.312mm
		6.050mm

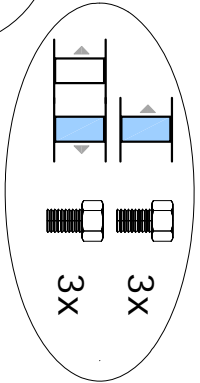
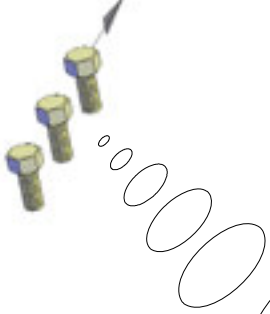
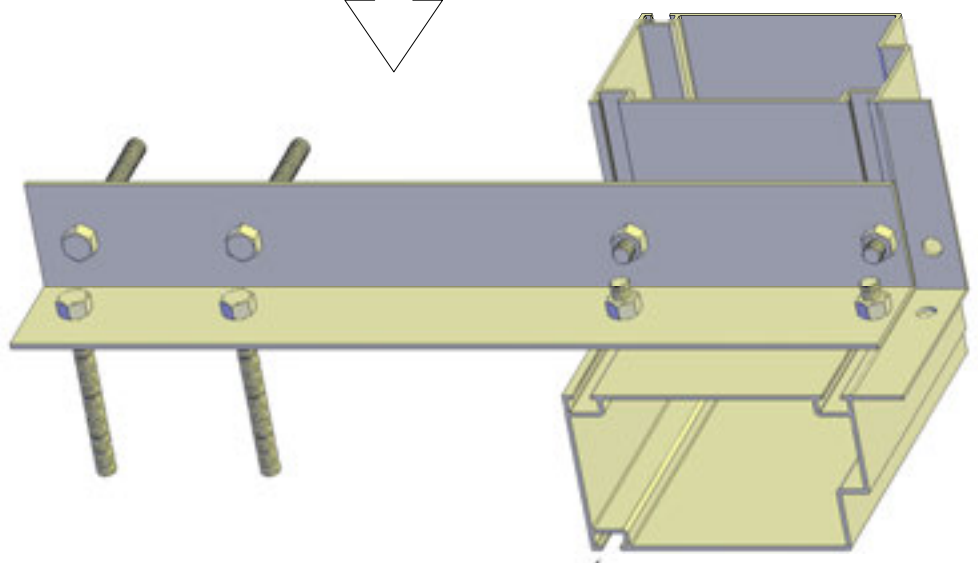
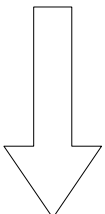
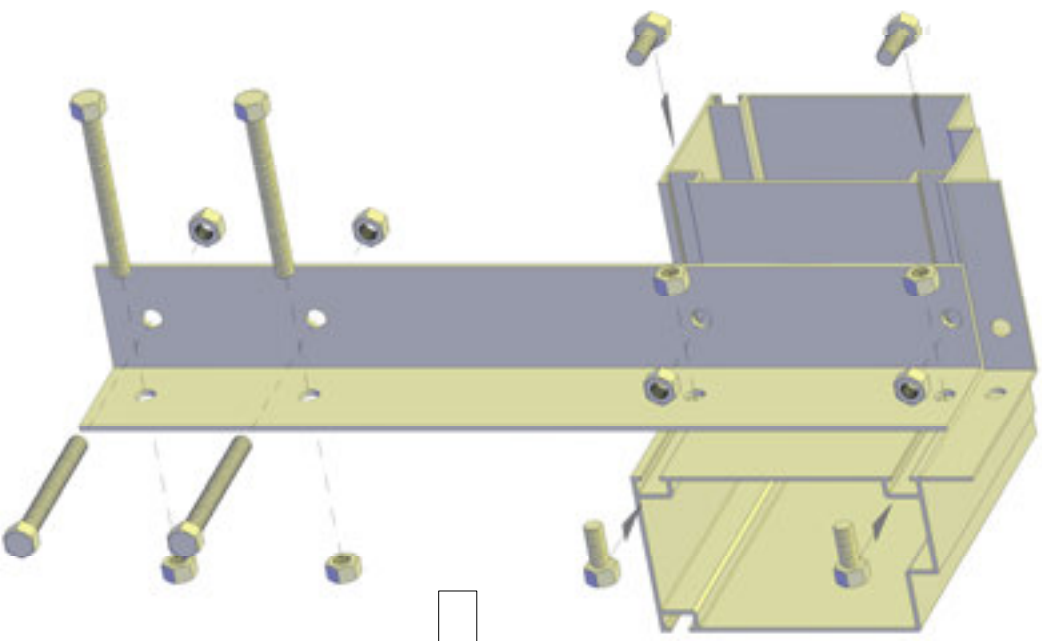
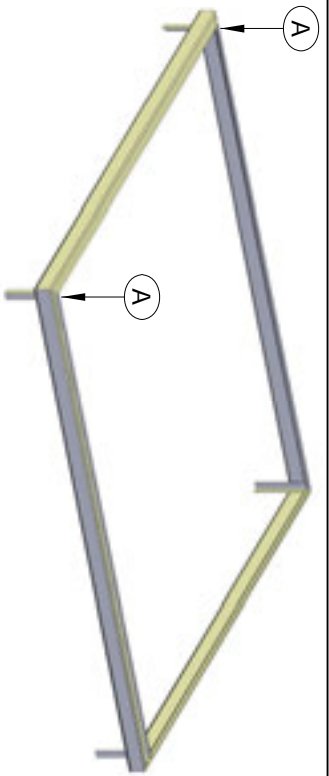







ITEM	PC.
 PRO210	4 pc.
 PRO6120	2 pc.
 PRO6120	2 pc.
 M6X15	32 pc
 M6X50	32 pc

MODERN 1

ITEM	PC.
 PR06578	4 PC.
 M6X15	16 PC.

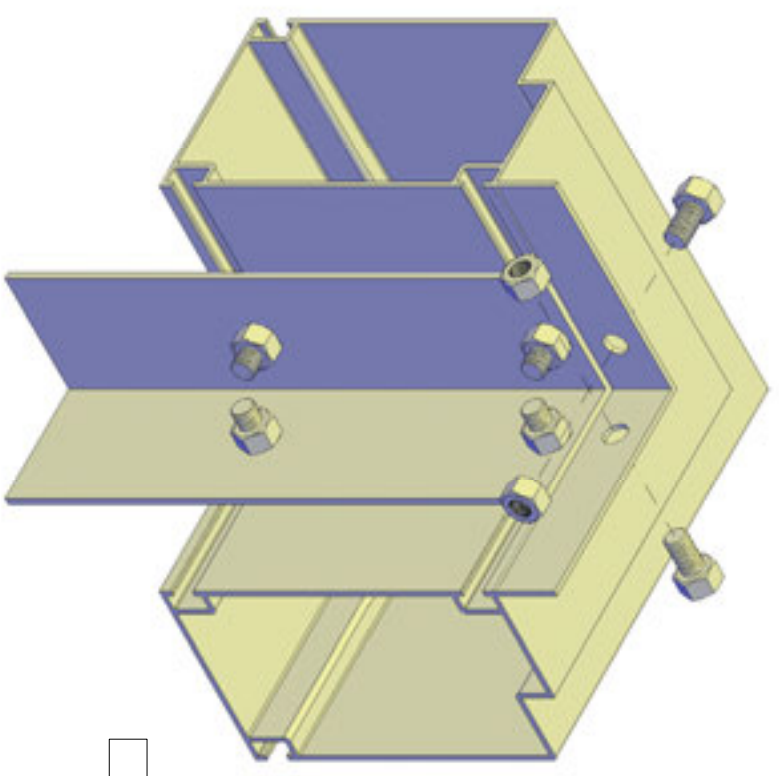
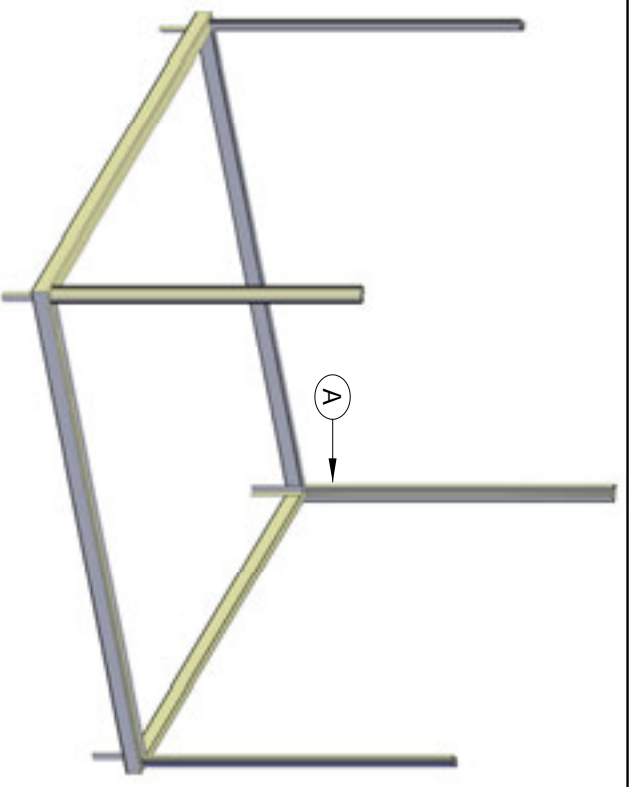

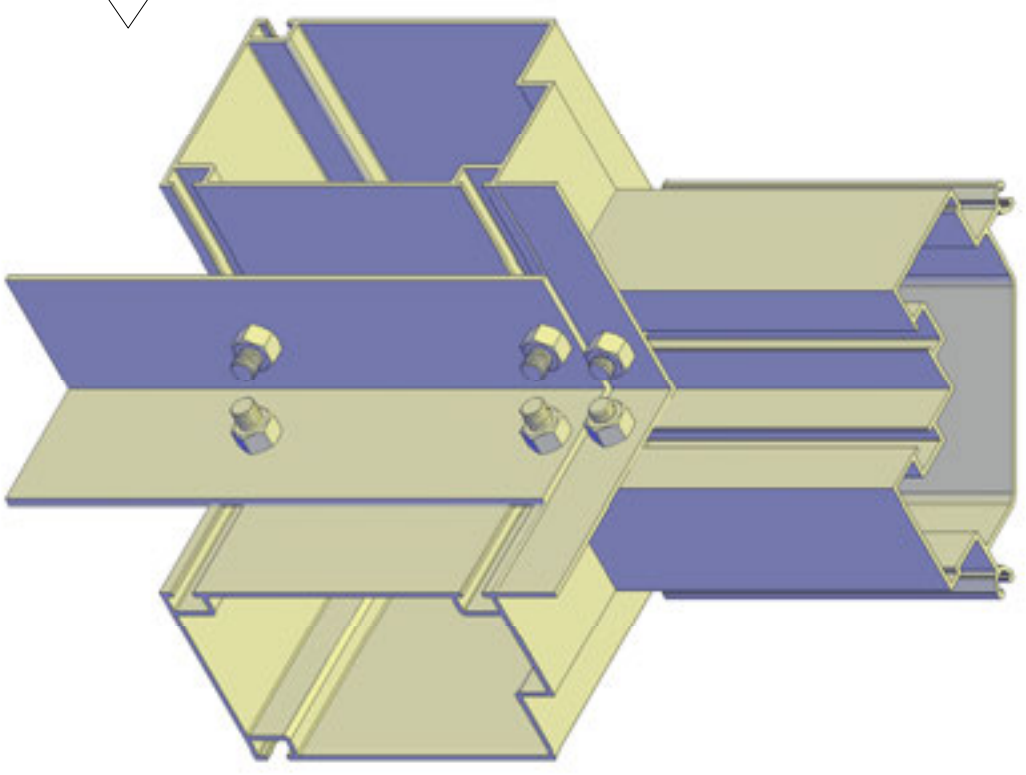
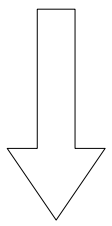

A

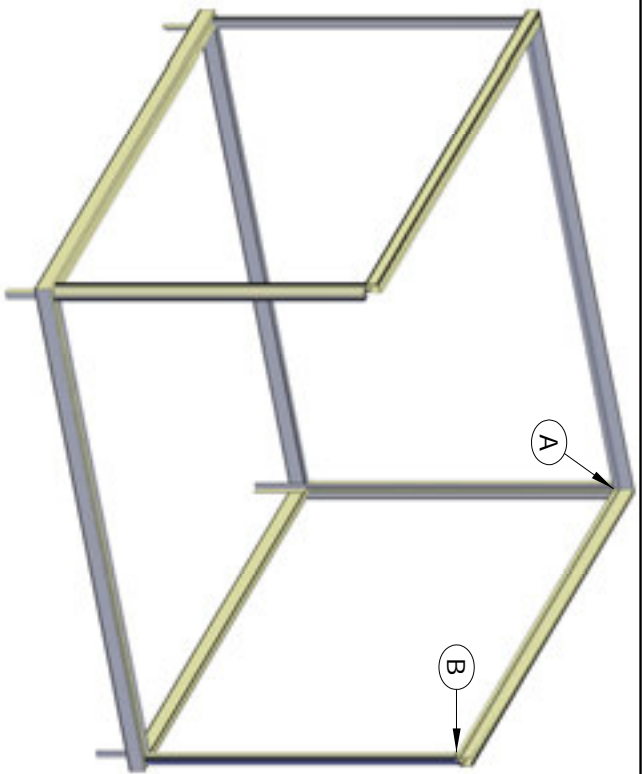

MODERN 2

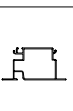
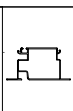



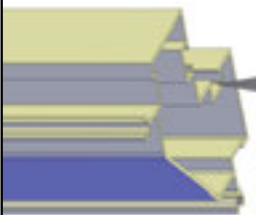
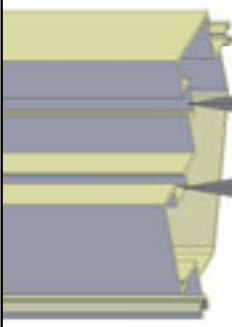
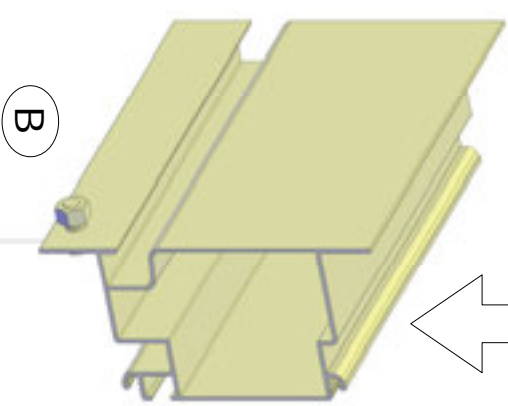
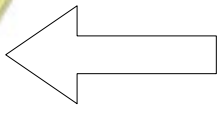
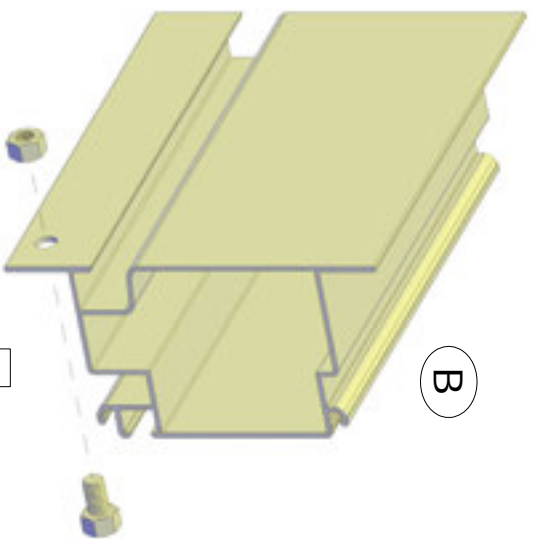
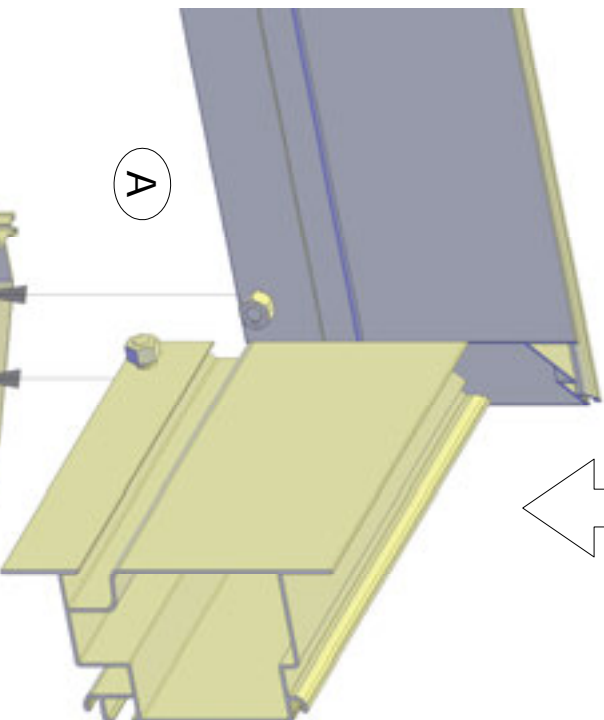
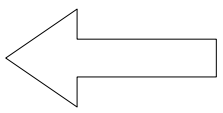
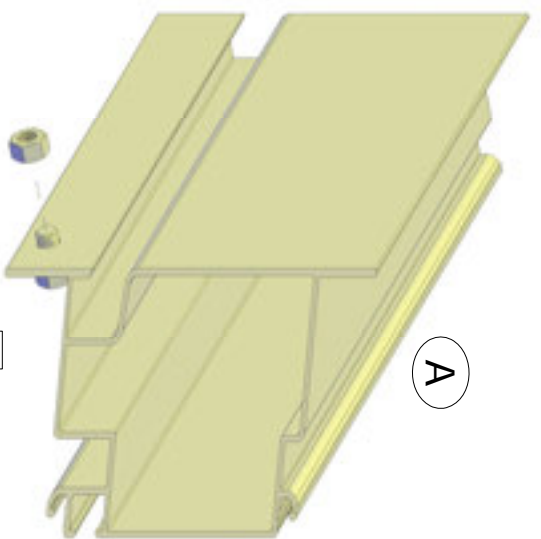

ITEM	PC.
	PR01454 2 PC.
	PR01454 1 PC.
	M6x15 6 PC.

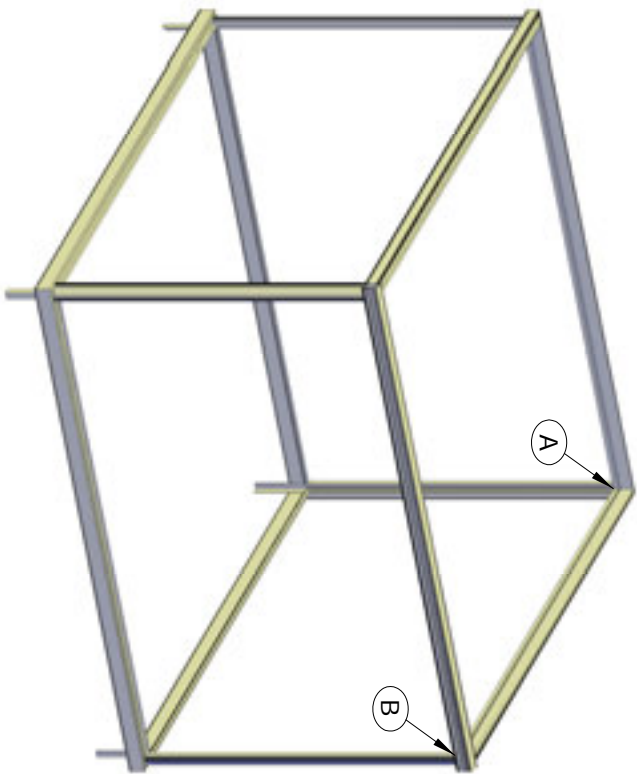

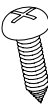



MODERN 3

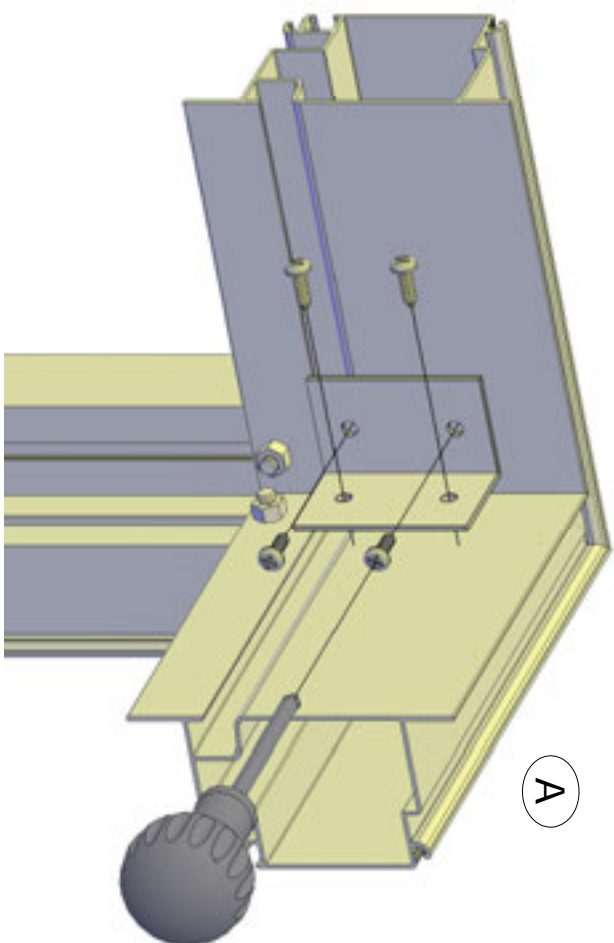
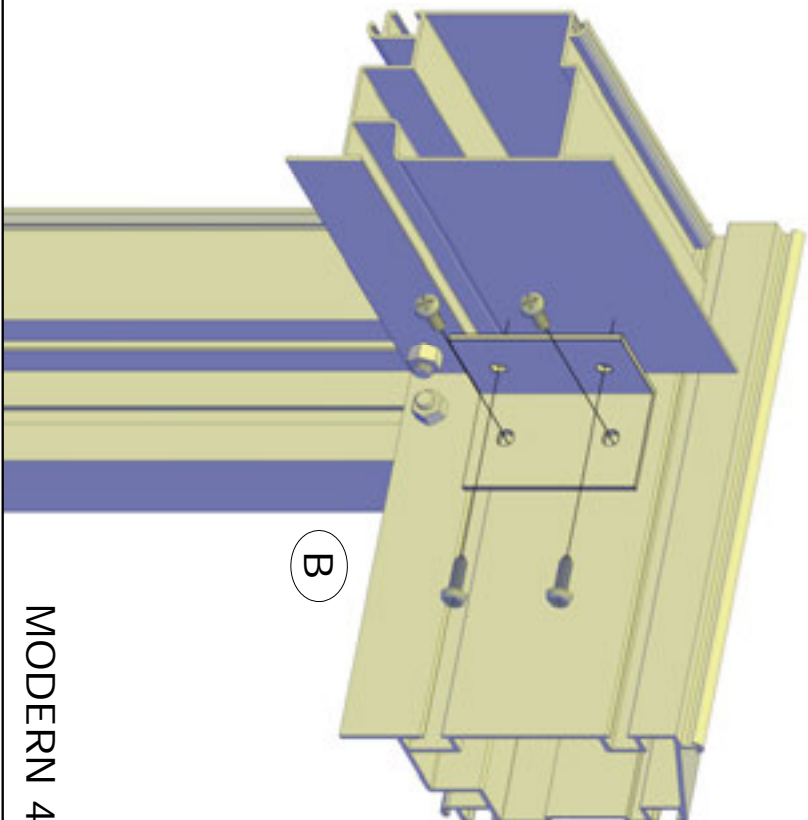
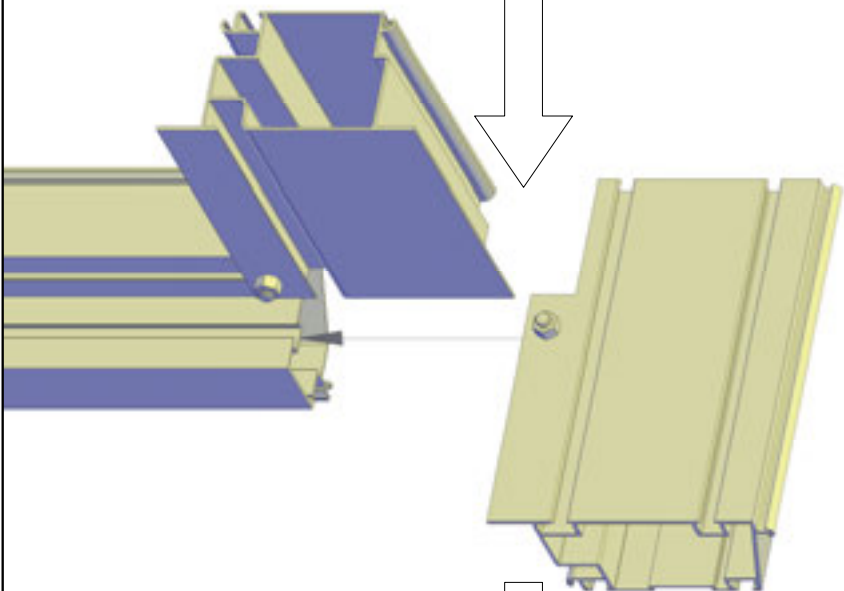
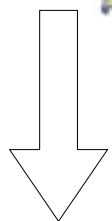
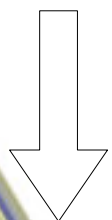



ITEM				
				
			M6x15	GDO

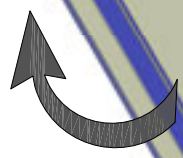
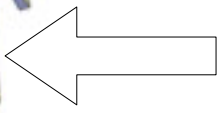
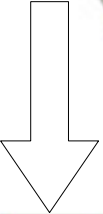
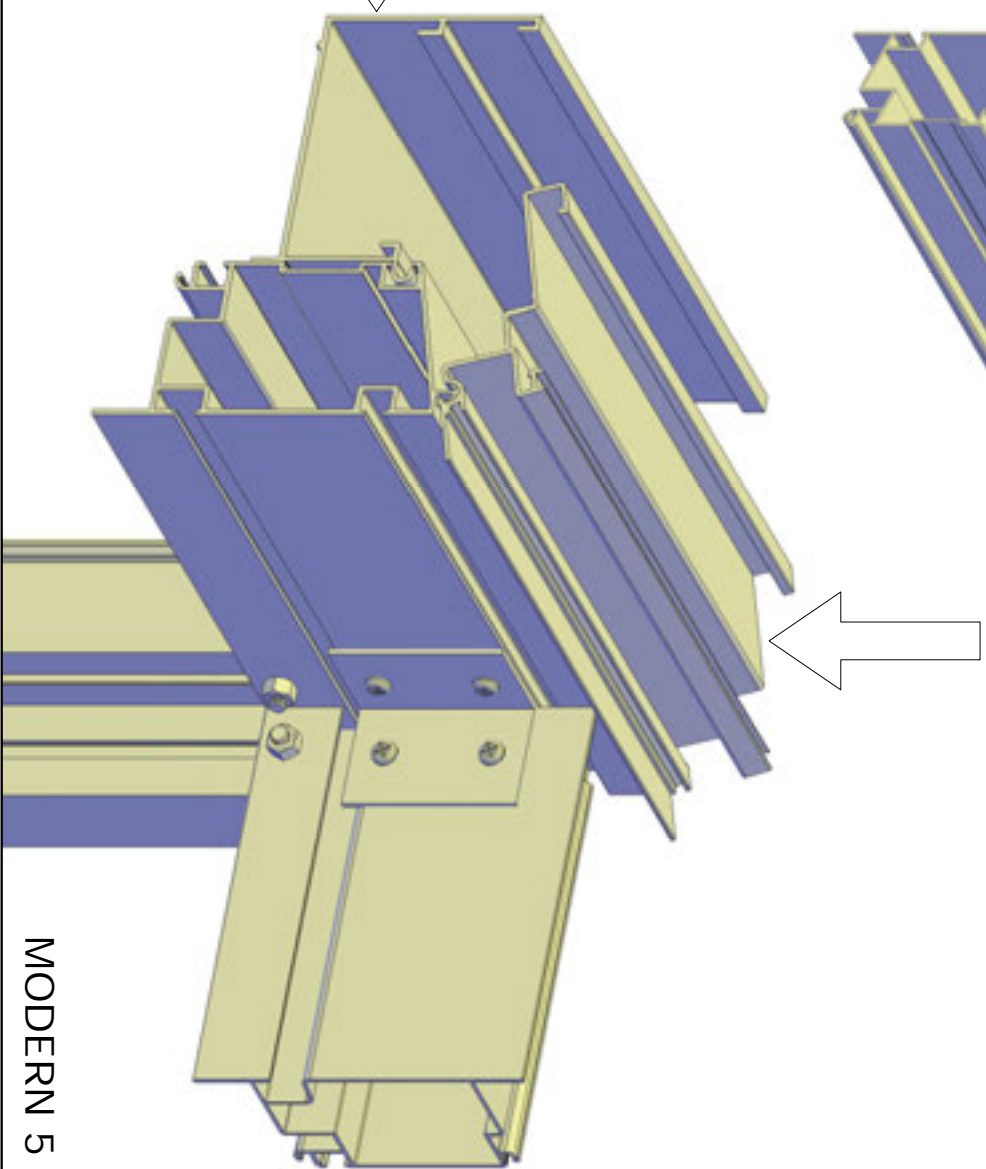
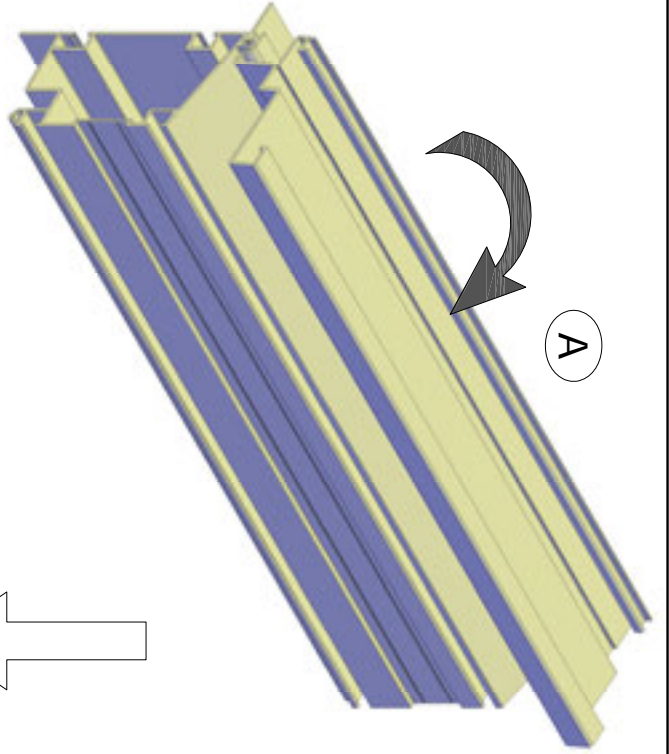
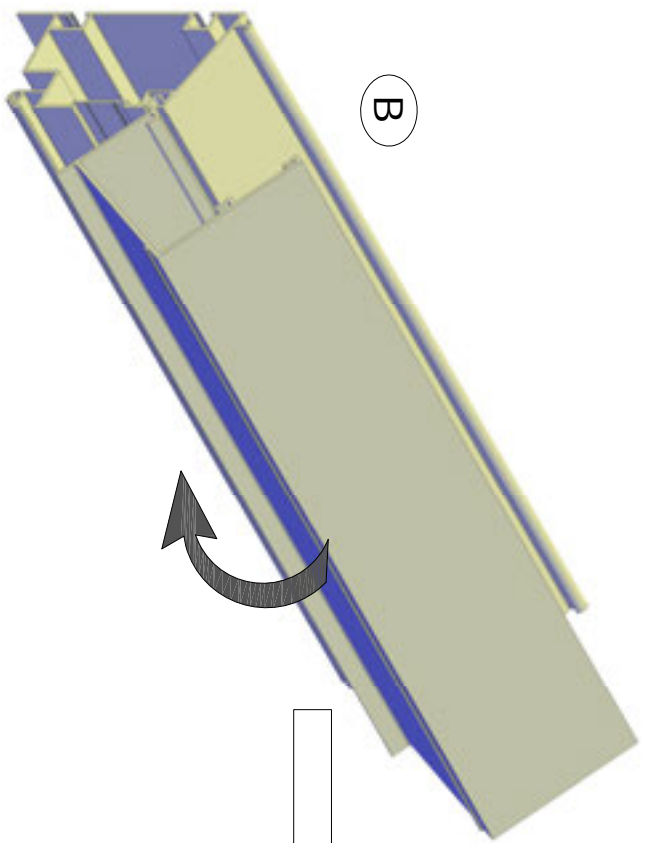
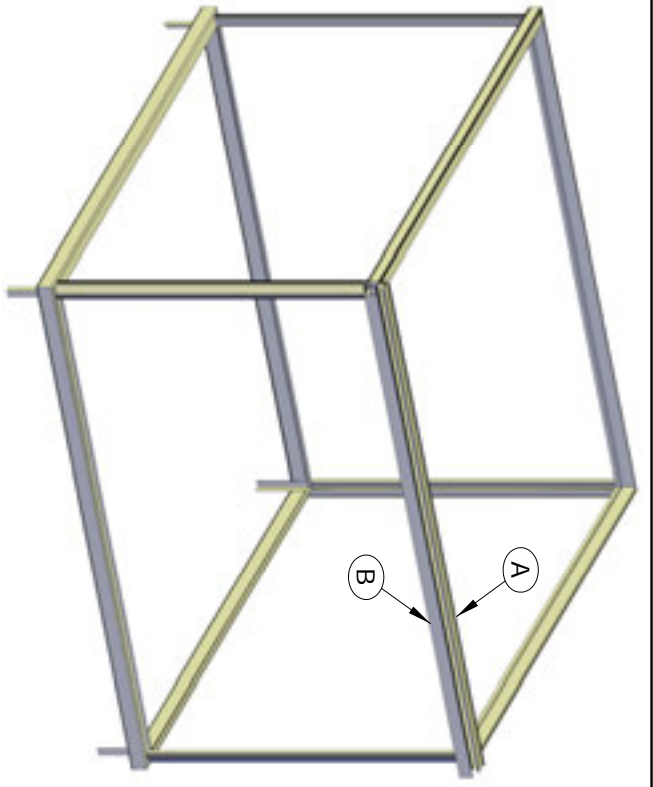

ITEM		
GSO		
GT0		



MODERN 5

ITEM			
PRO1456			
PRO6578			
M6x15			

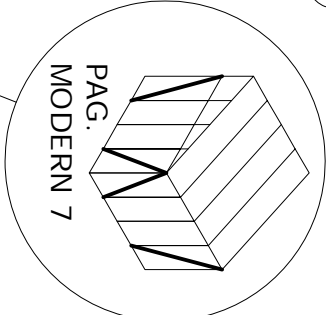
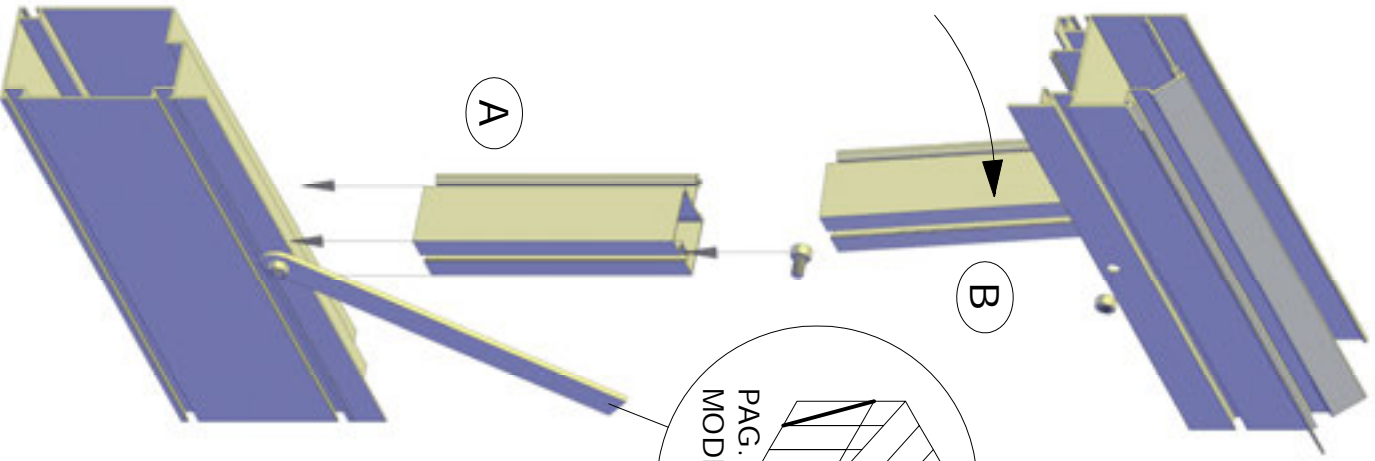
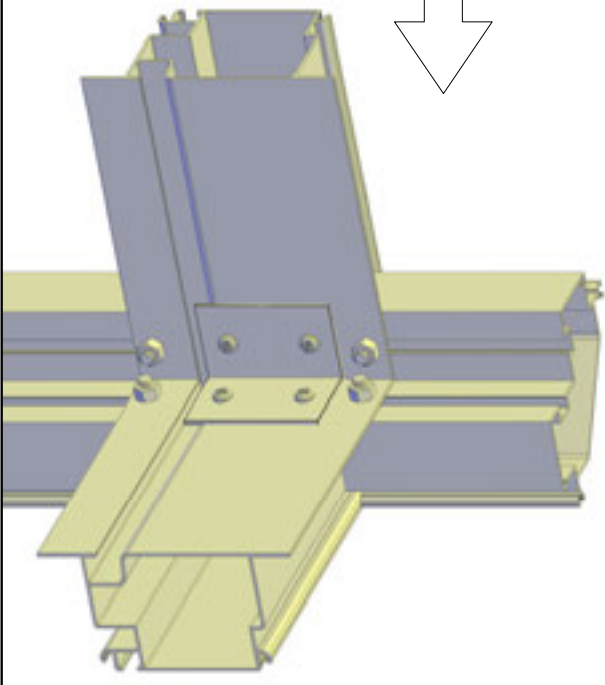
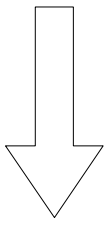
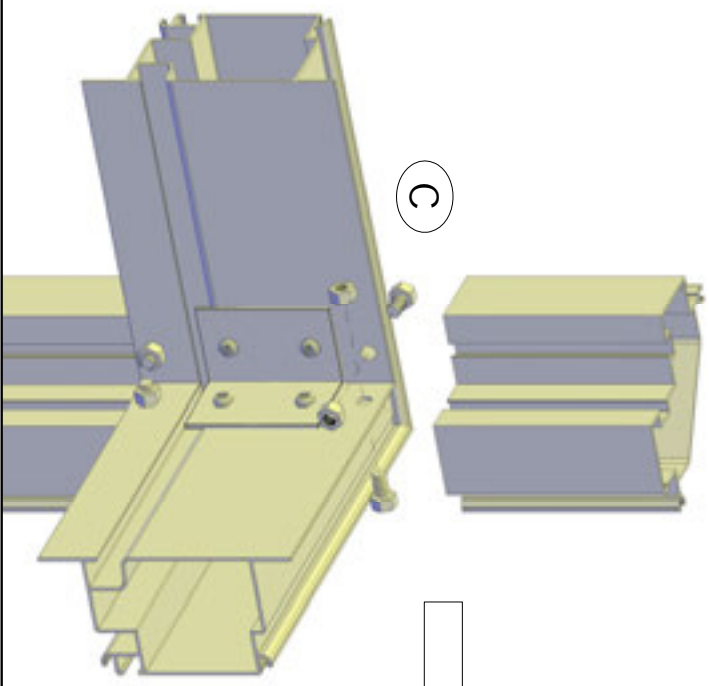
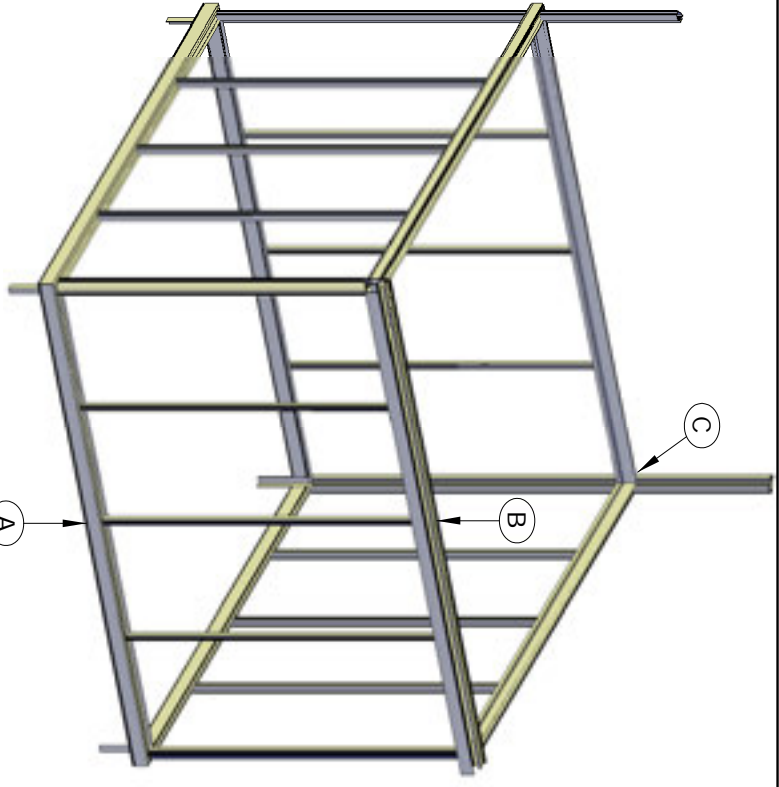

MODERN 6

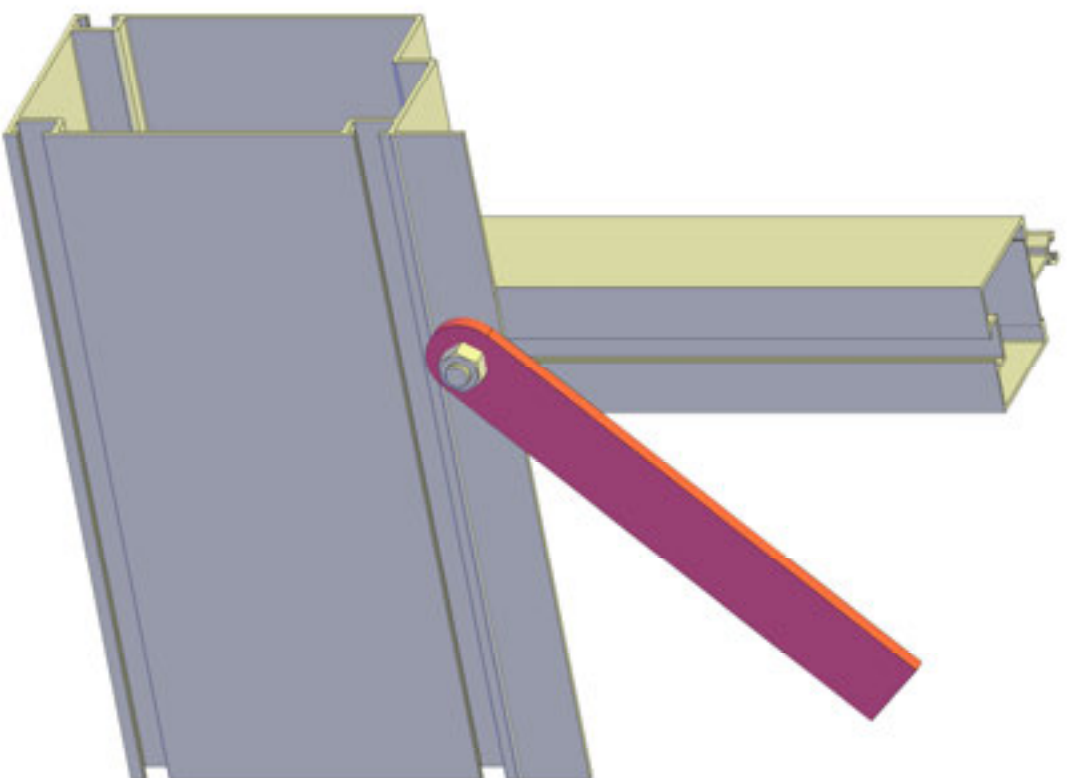



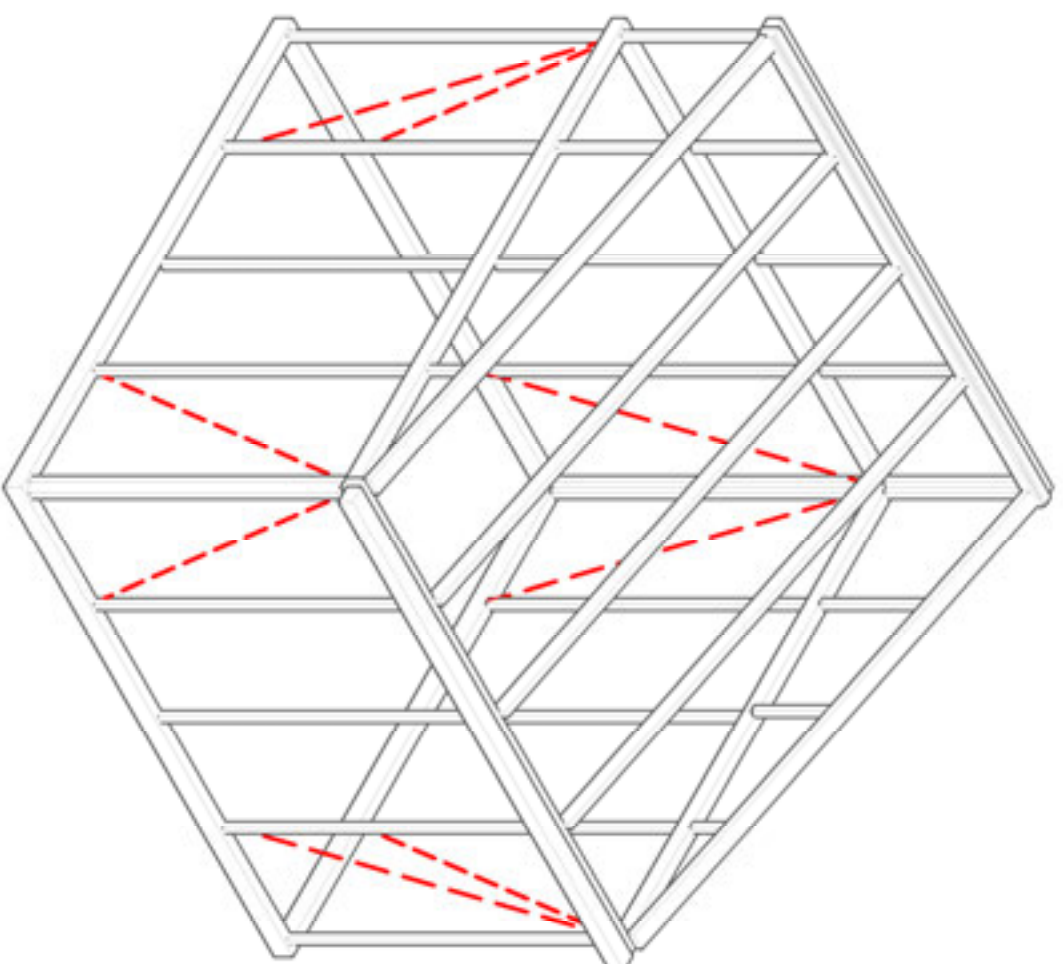

ITEM	PC.	L
TRE	8 pc.	1.975 mm

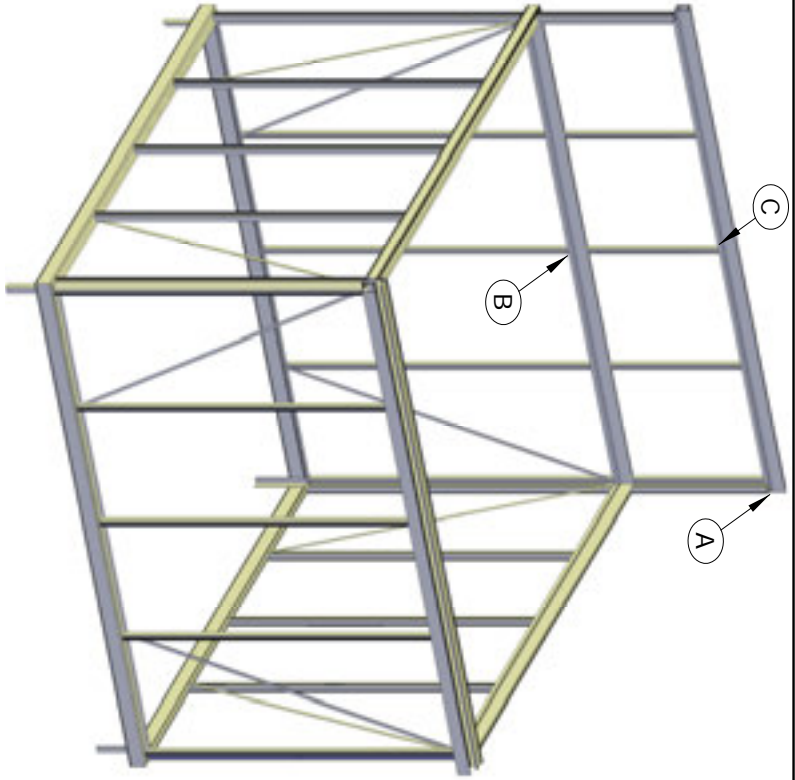
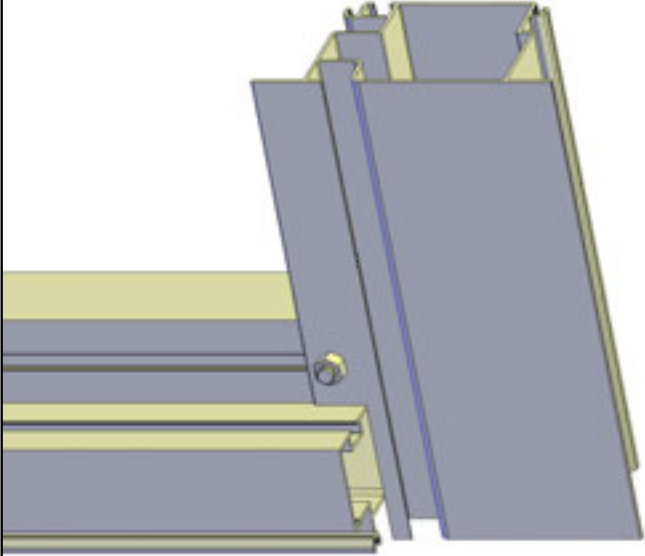
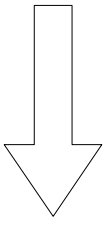
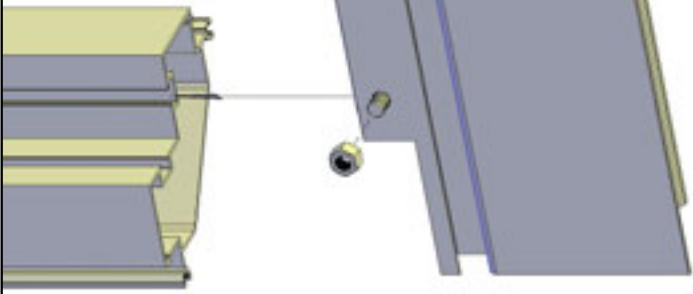

MODERN 7

A



ITEM			
M6X15		PR01456	PR01454

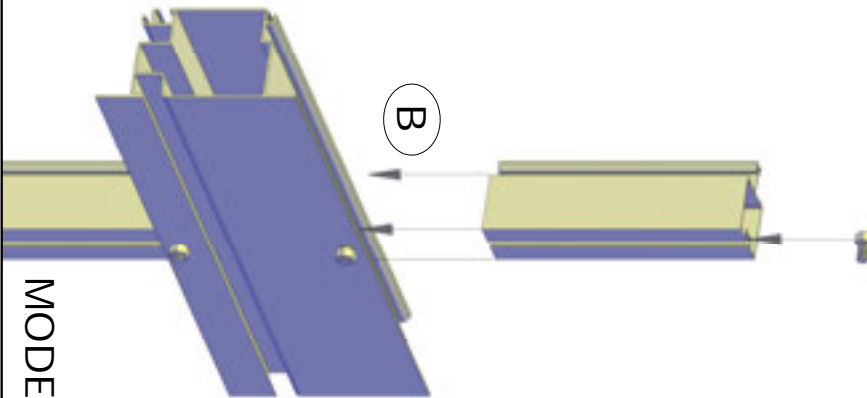

B

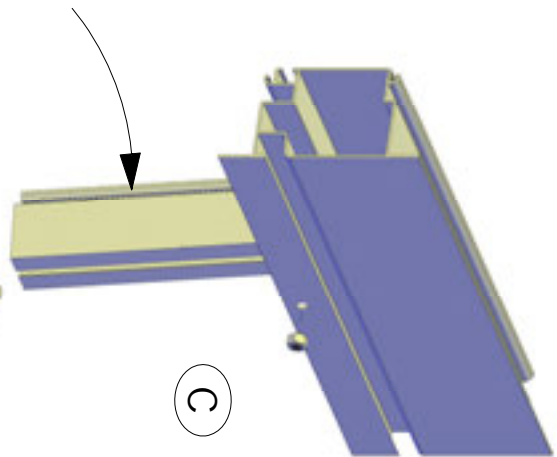

C



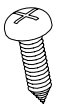

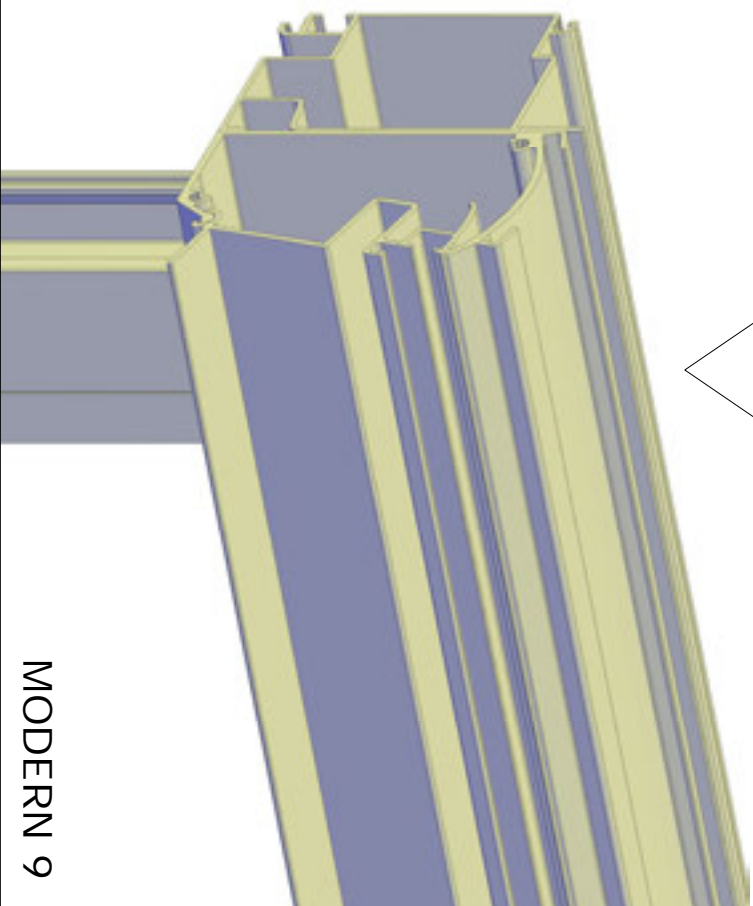
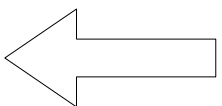
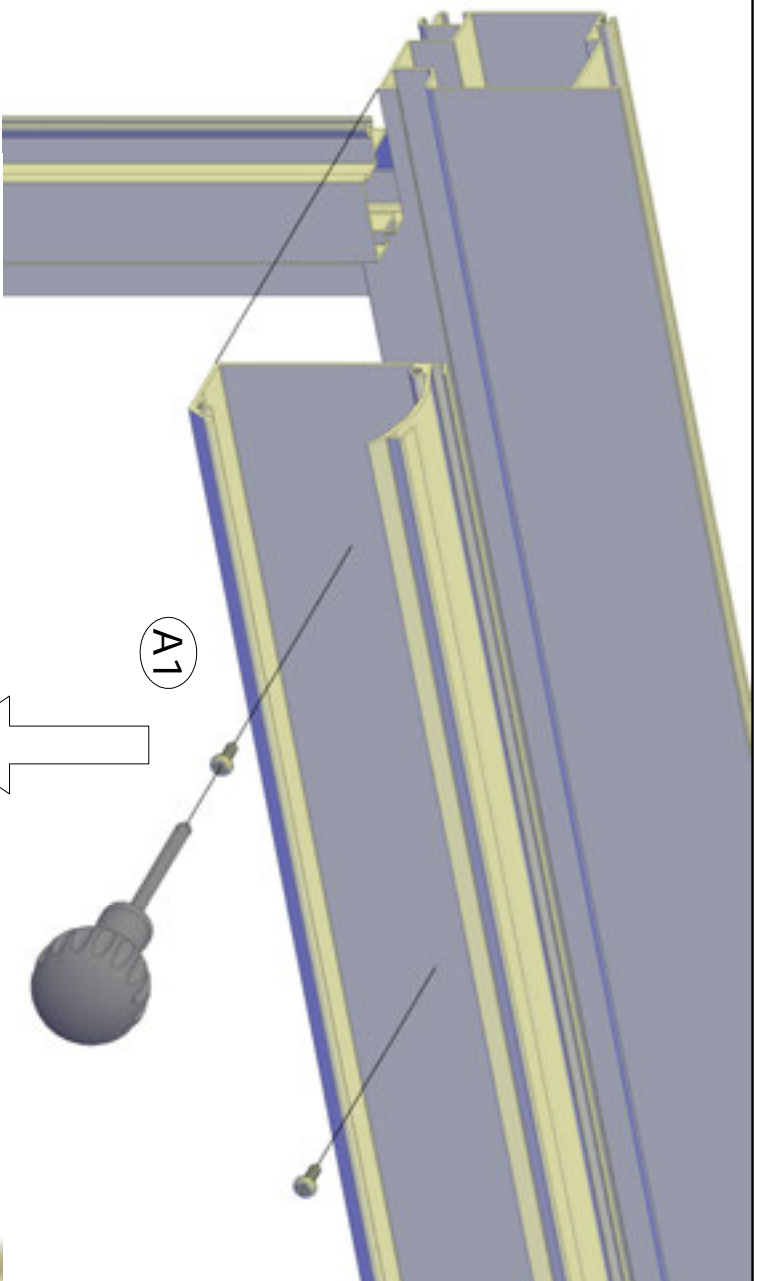
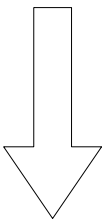
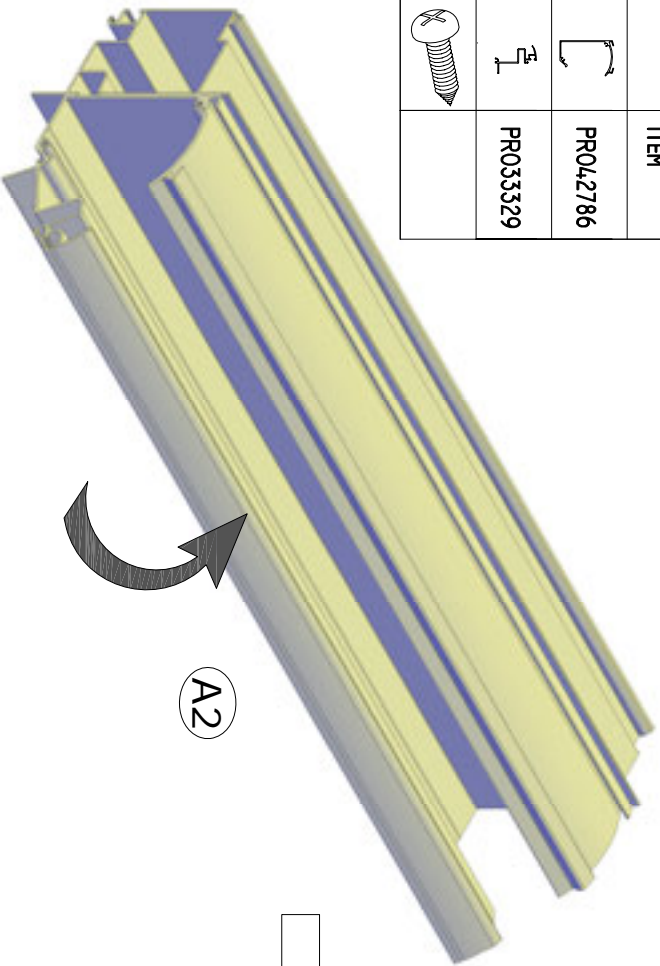
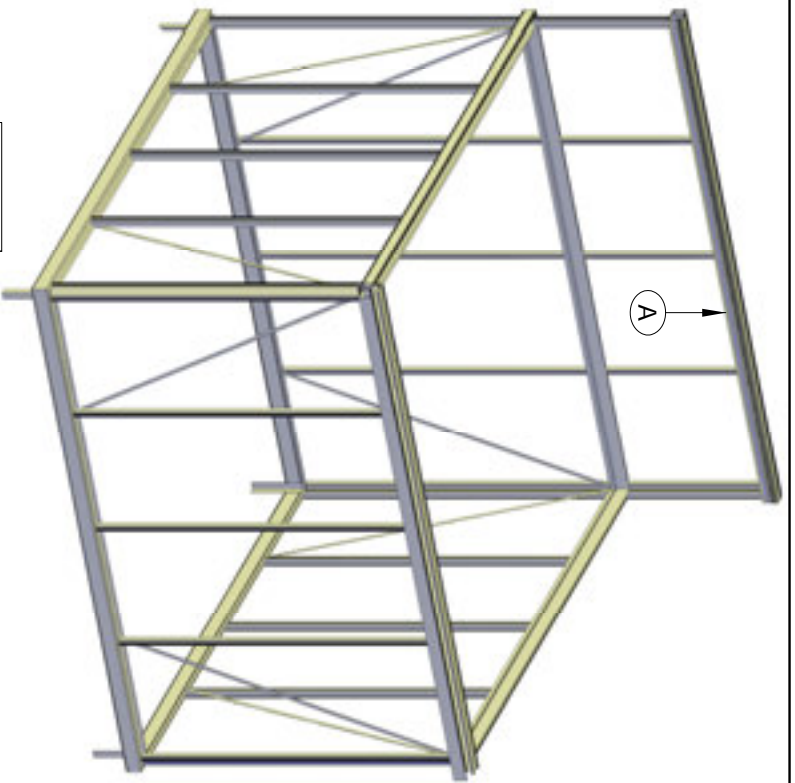

MODERN 8

		ITEM
	PR035329	PR042786

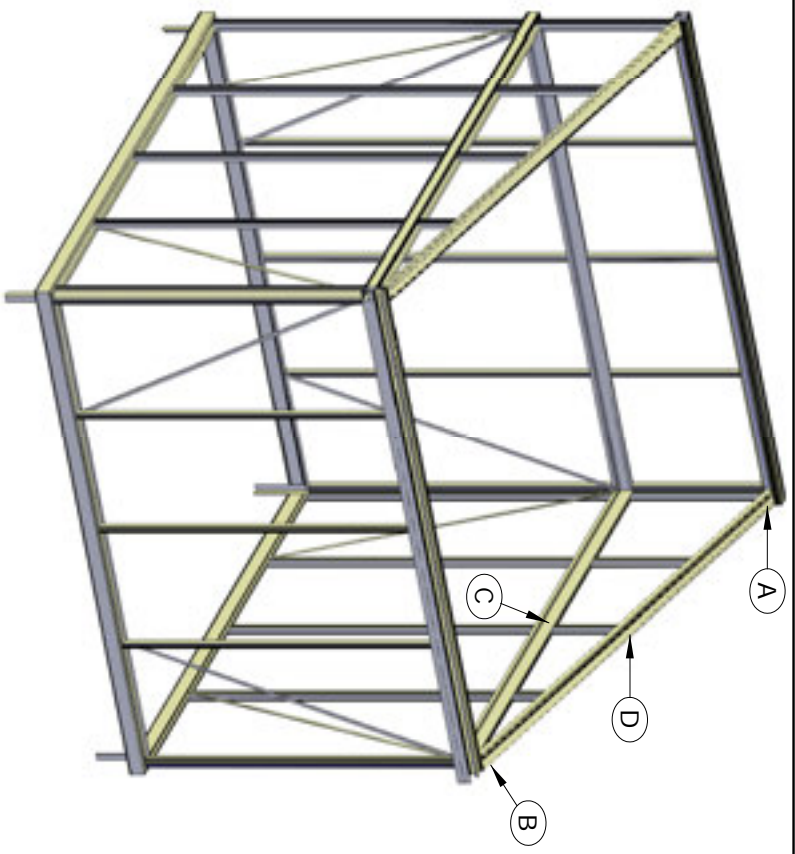

MODERN 9



ITEM		
PR06918		
PR01456		
M6x15		
L6		

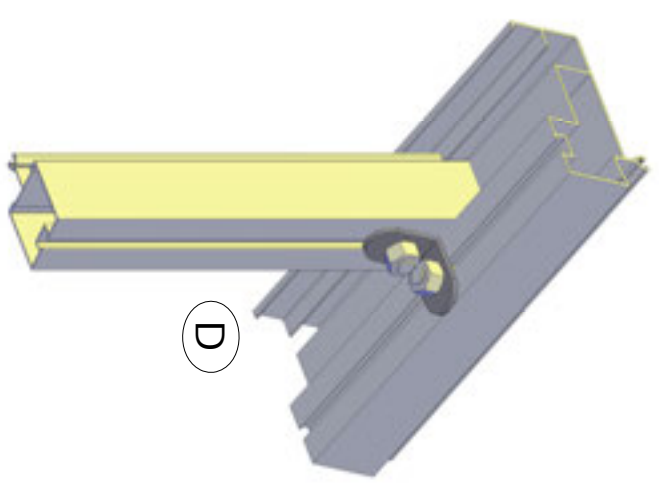
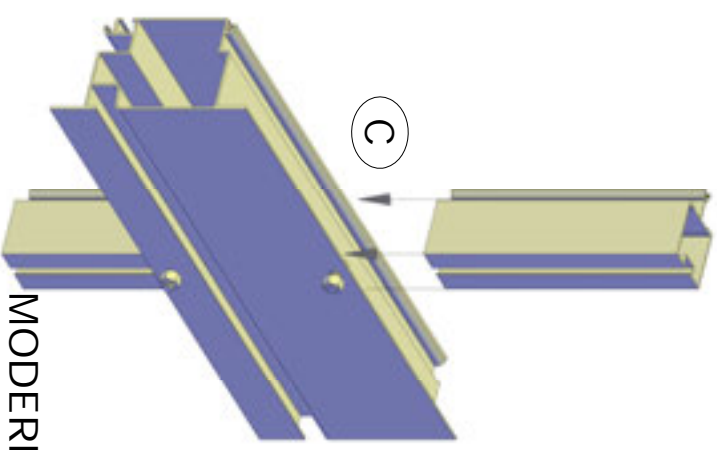
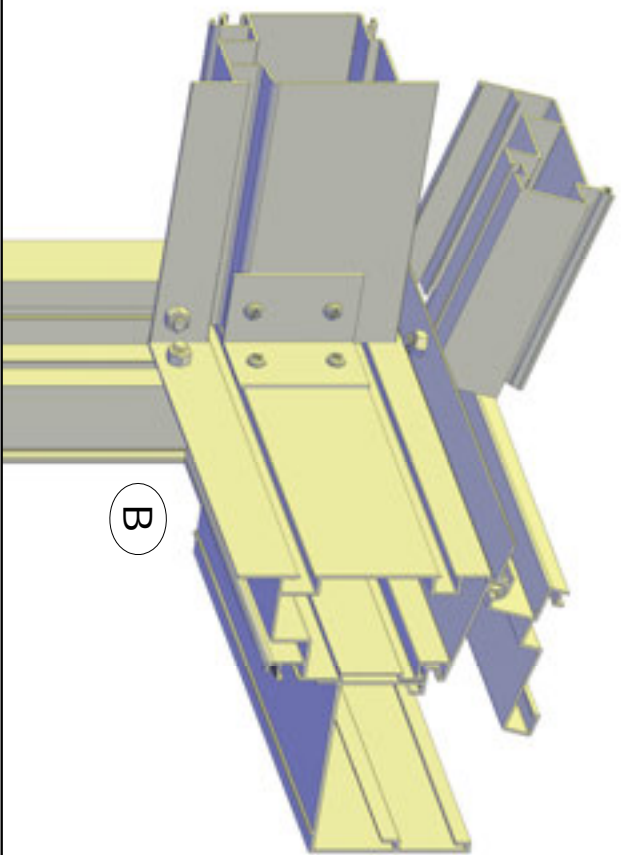
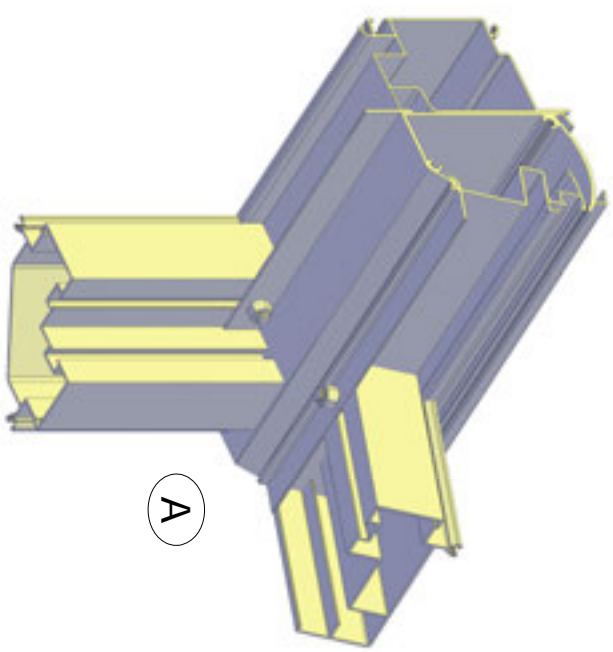

MODERN 10

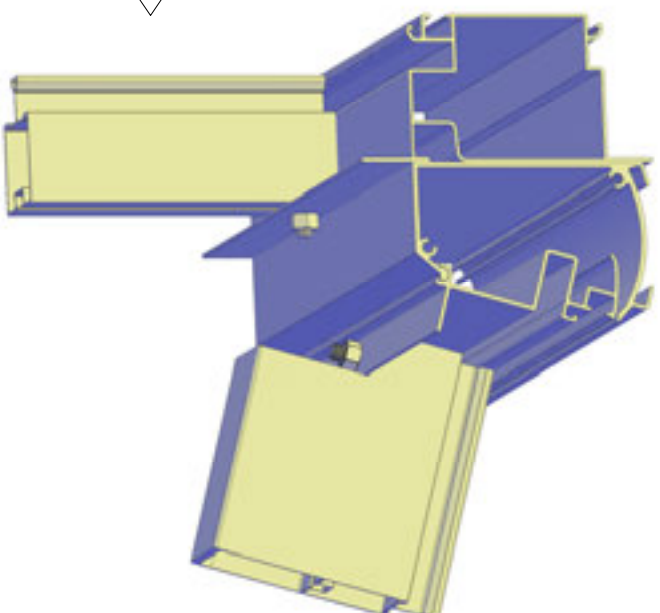
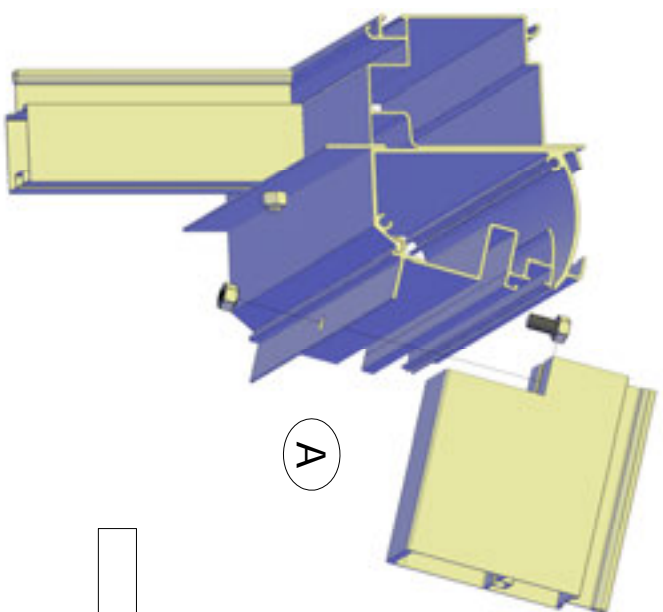
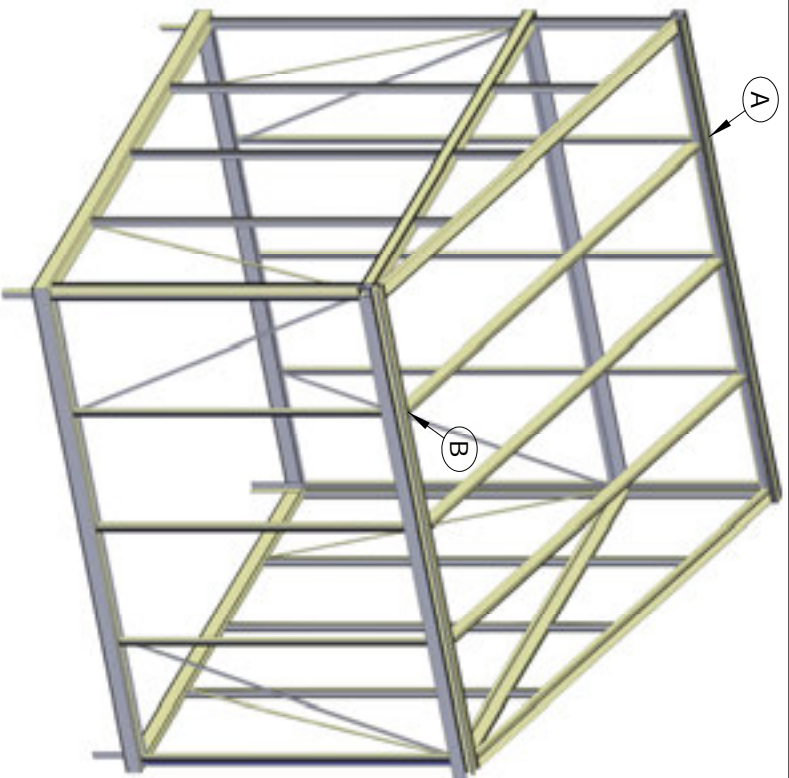

ITEM	PR033325
M6X15	

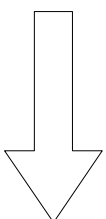
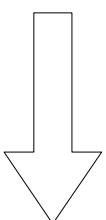
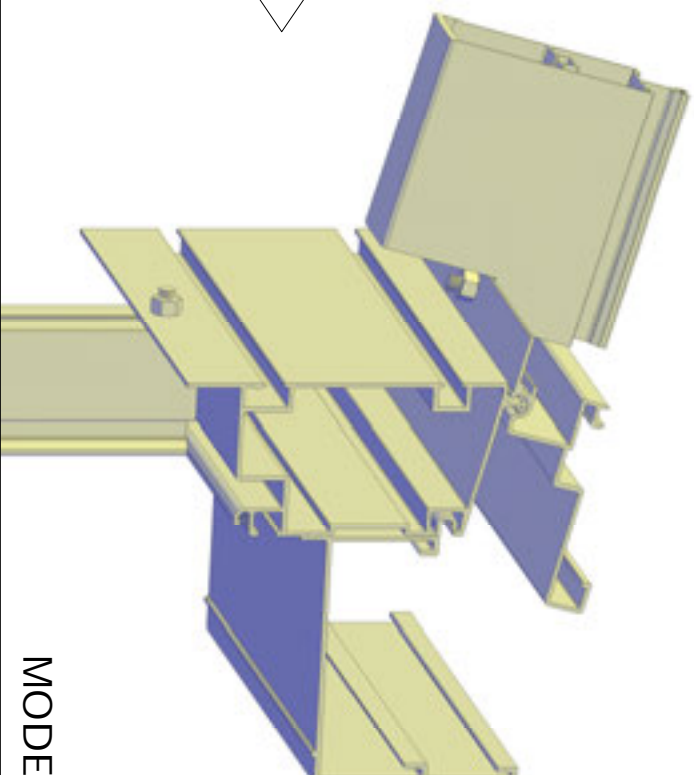
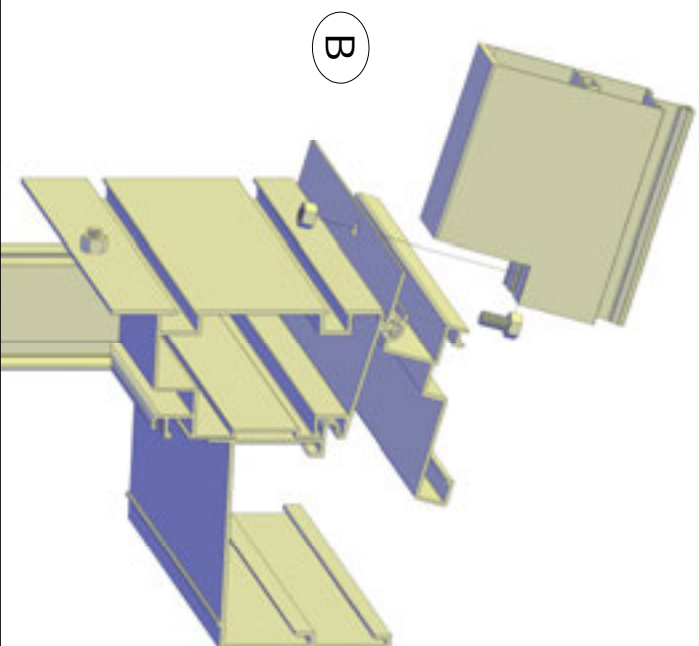

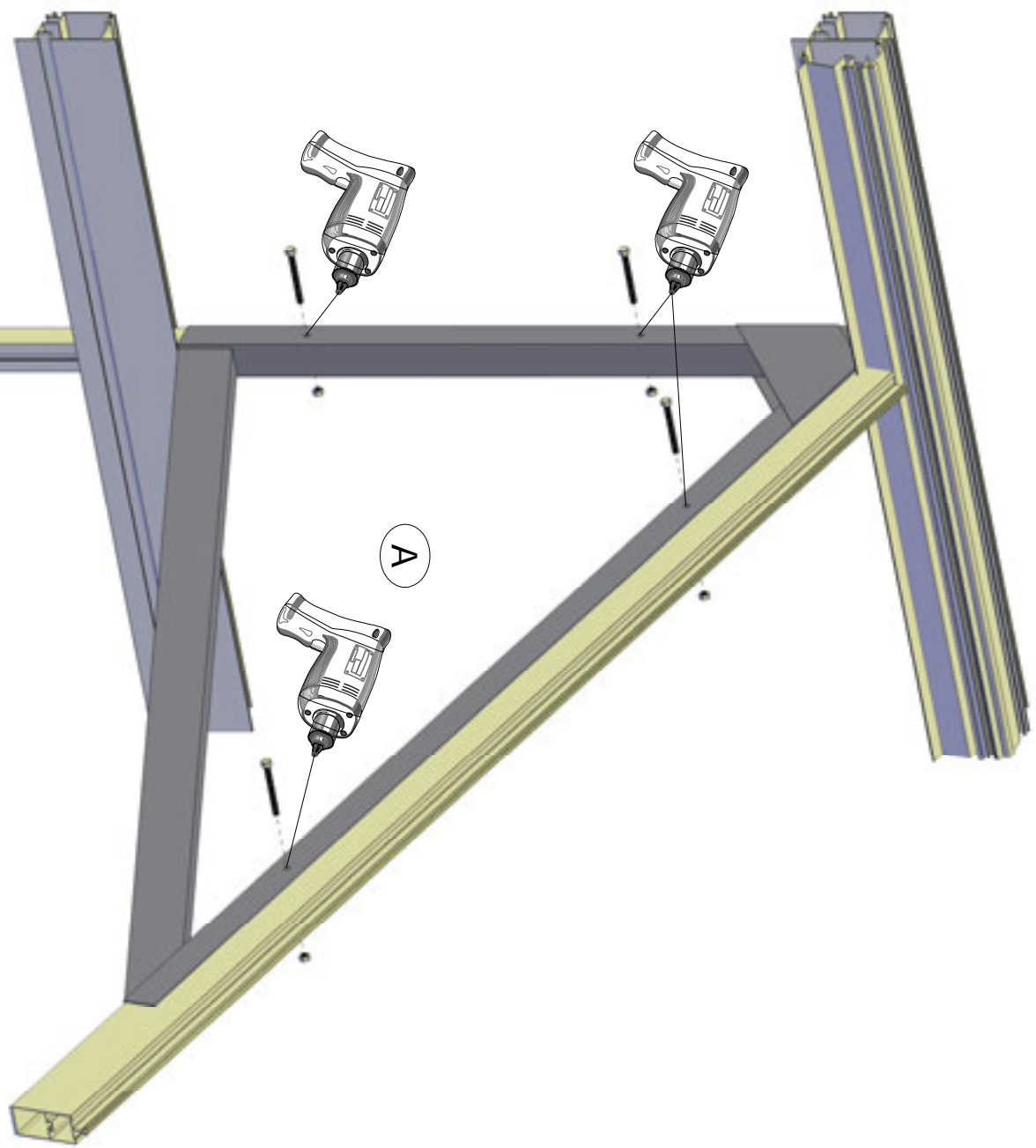
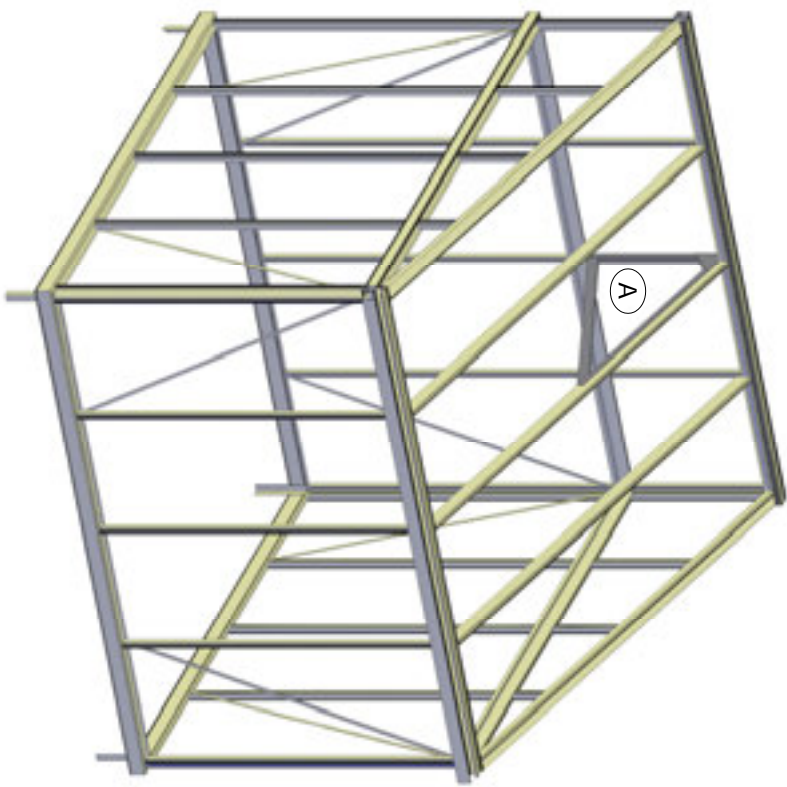

MODERN 12

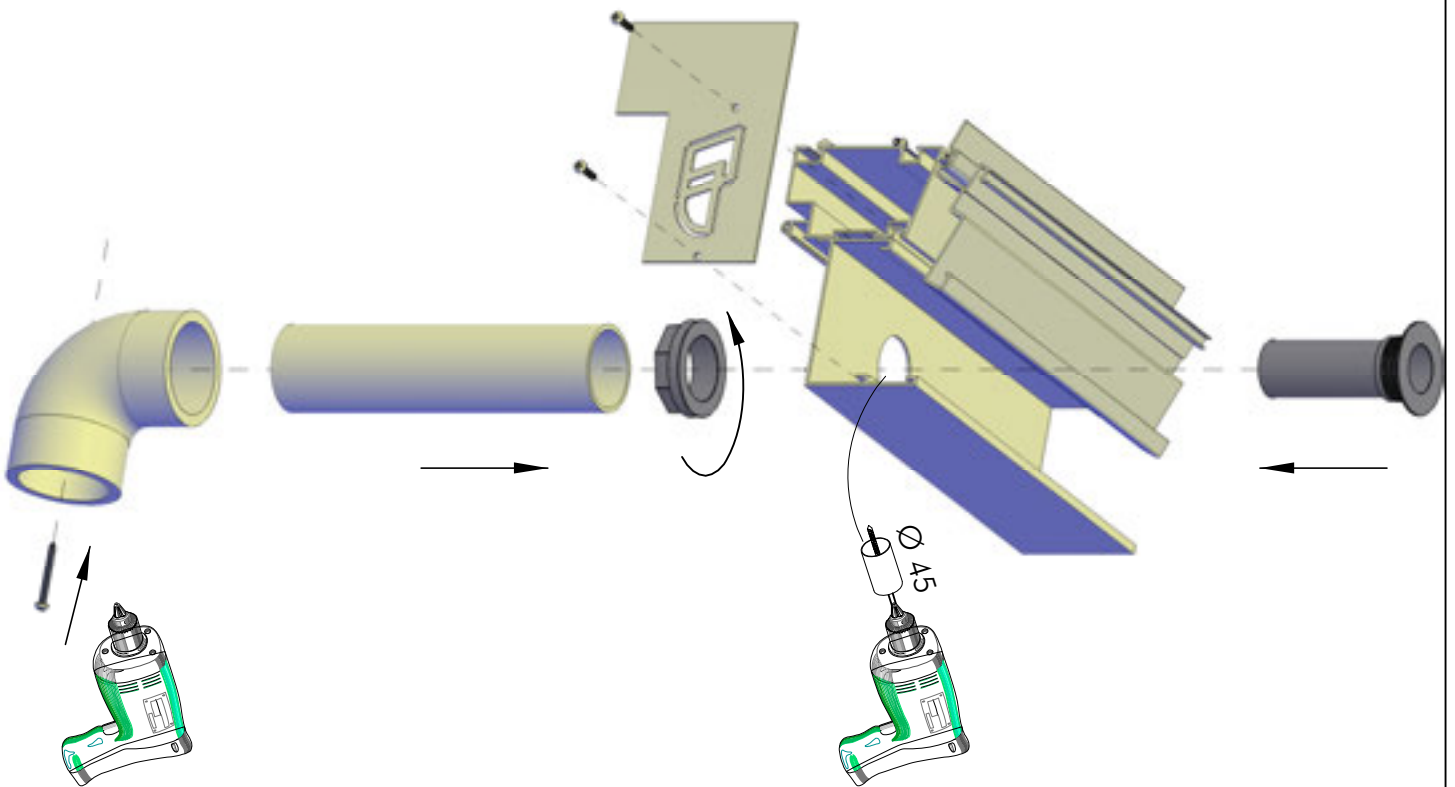
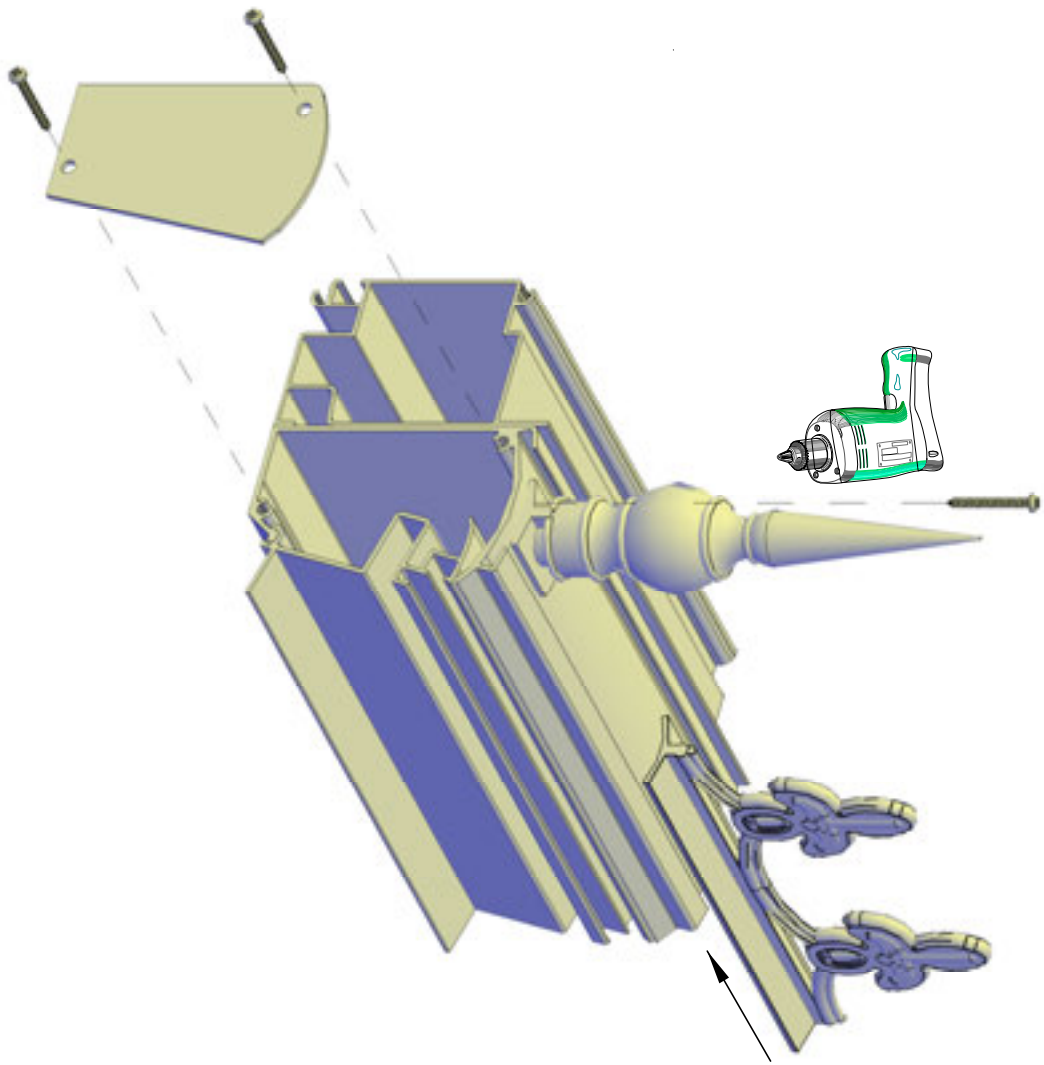

MODERN 13

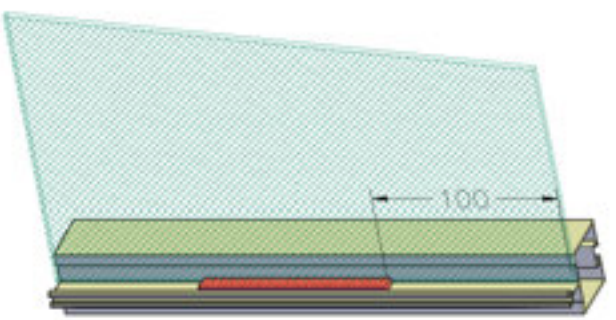
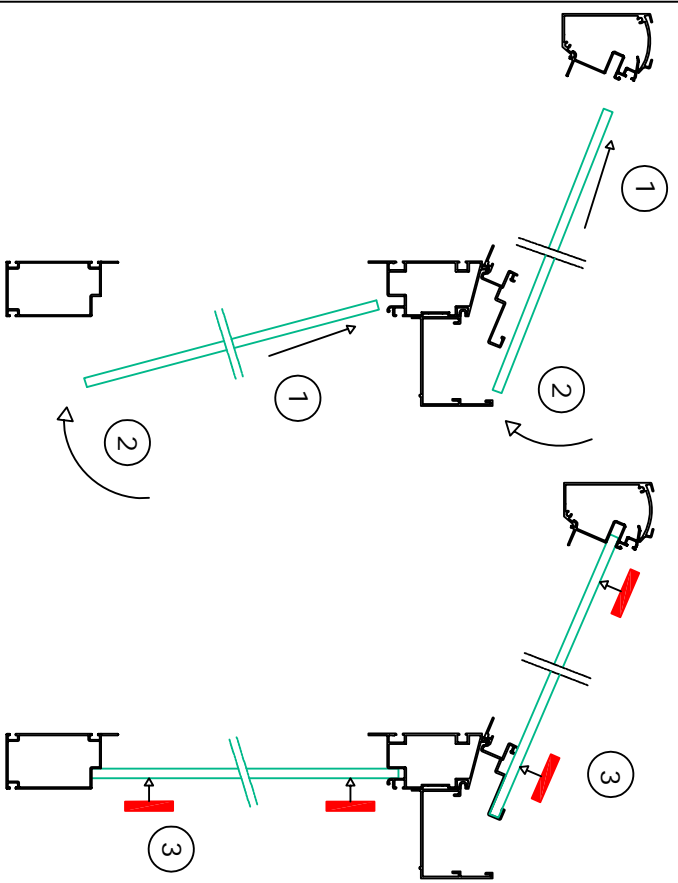

③ SILICONEN

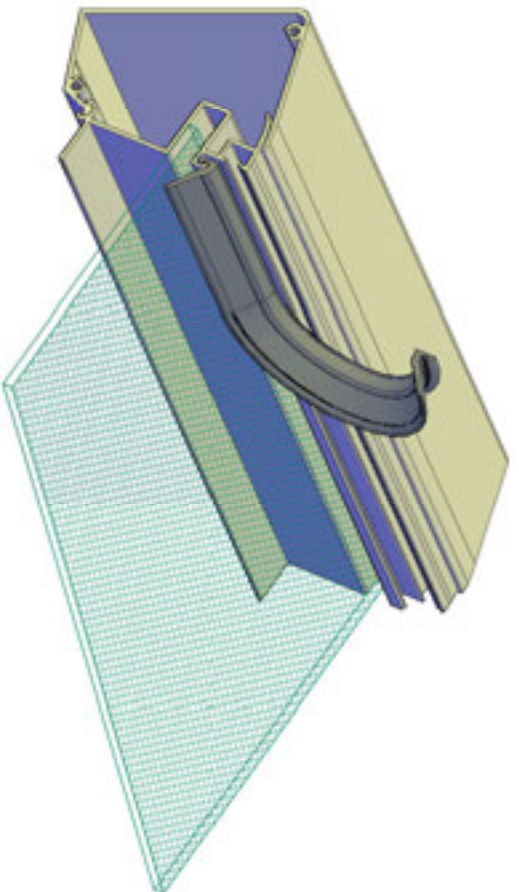
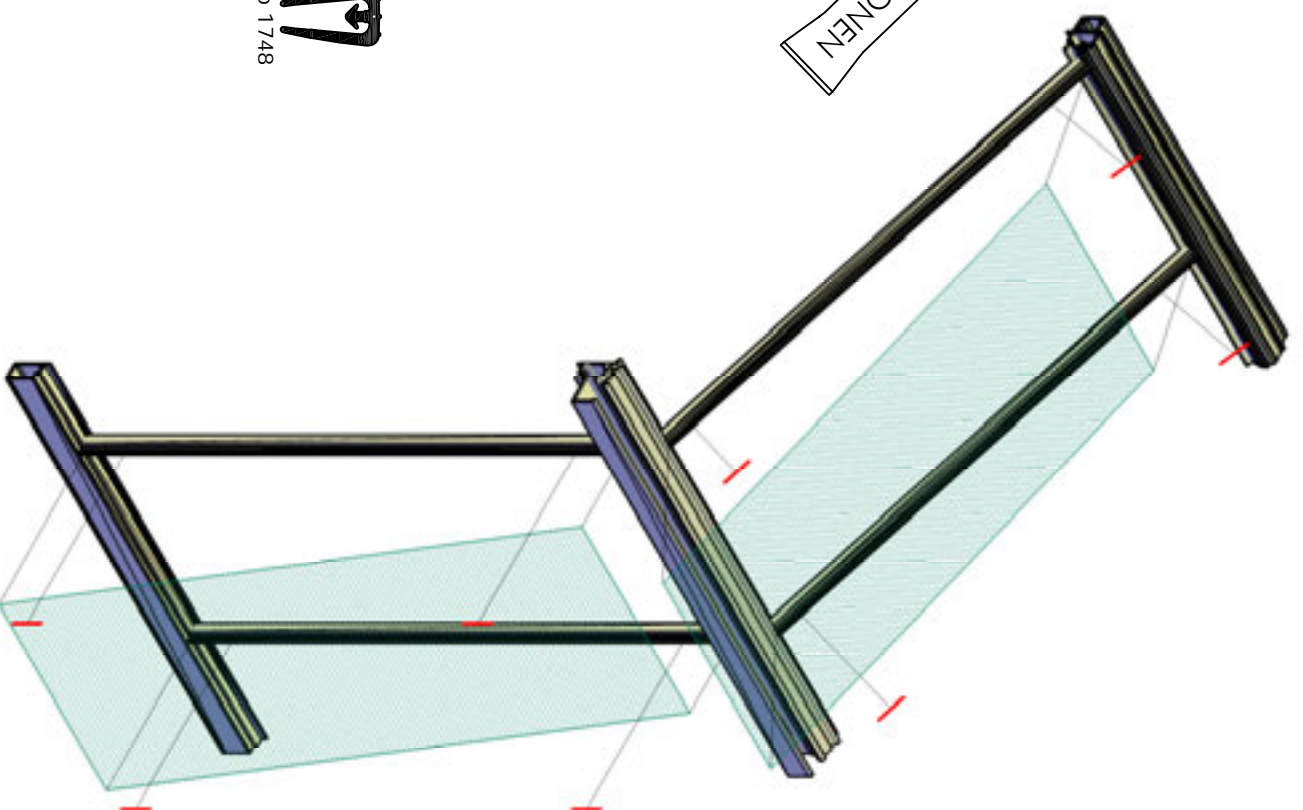

⑤



Pro 5538

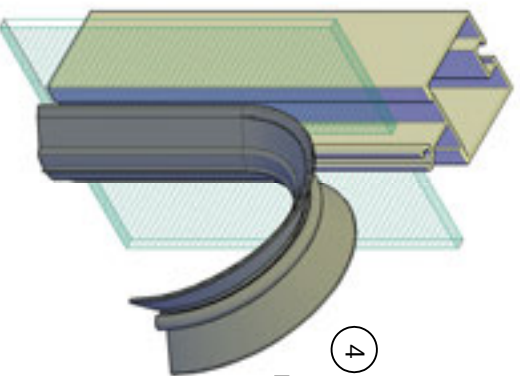

④



Pro 1748

MODERN 14

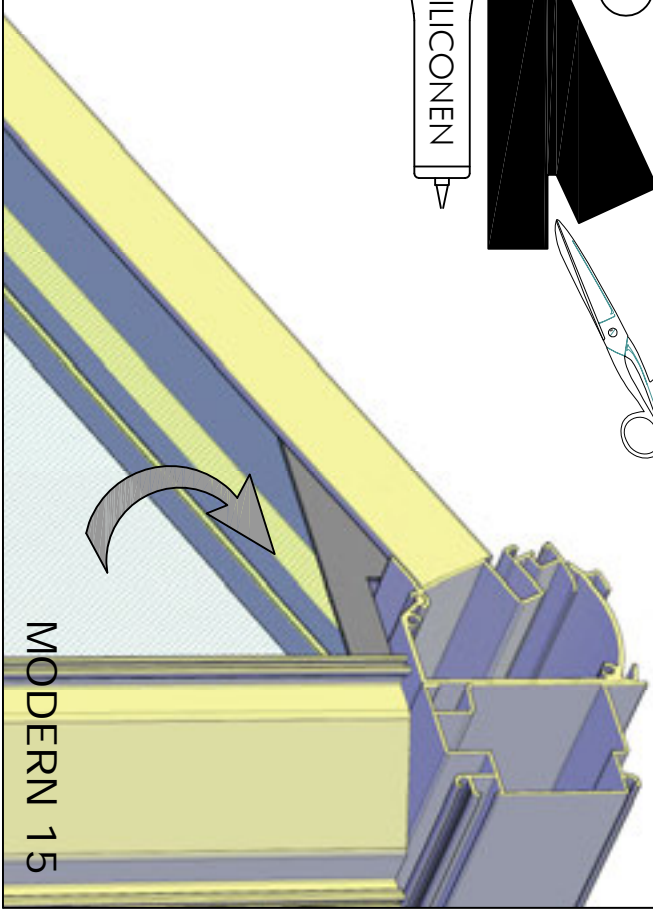
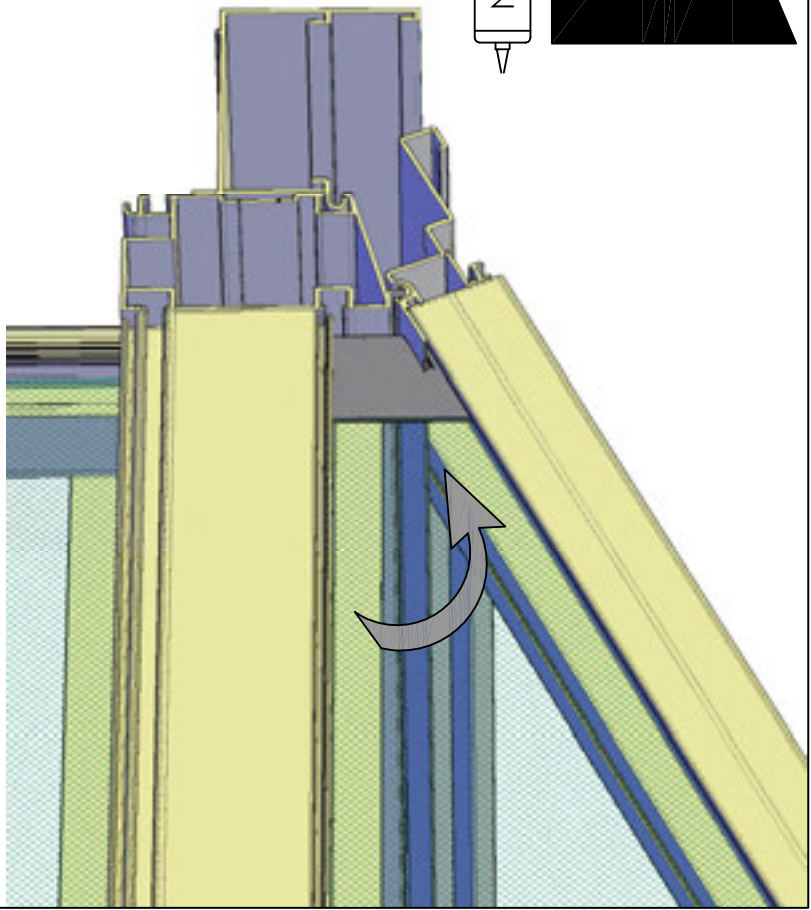
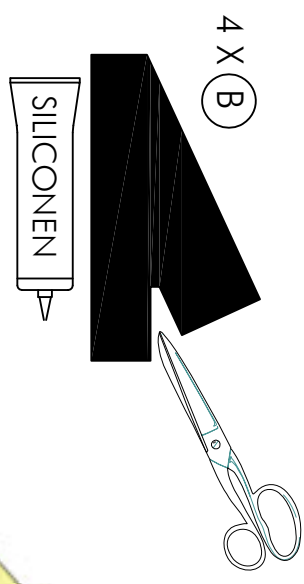
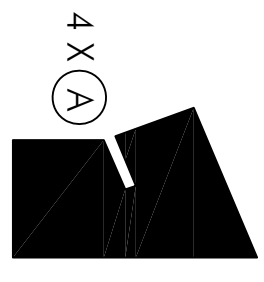
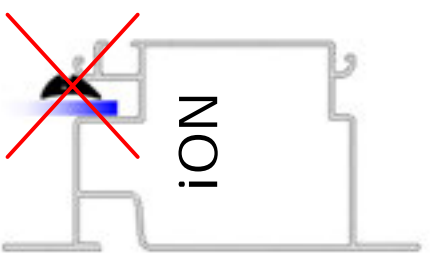
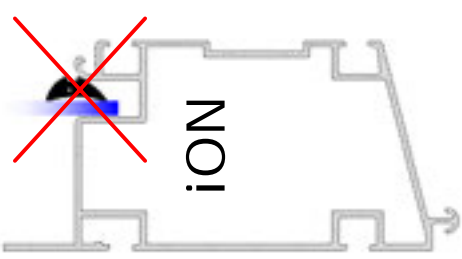
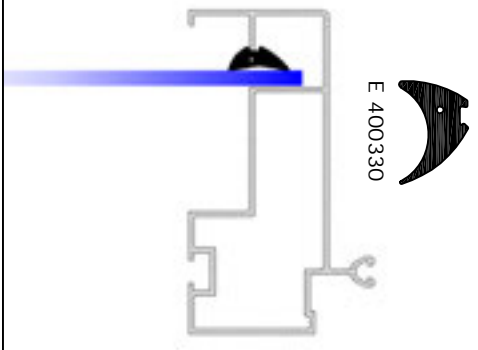
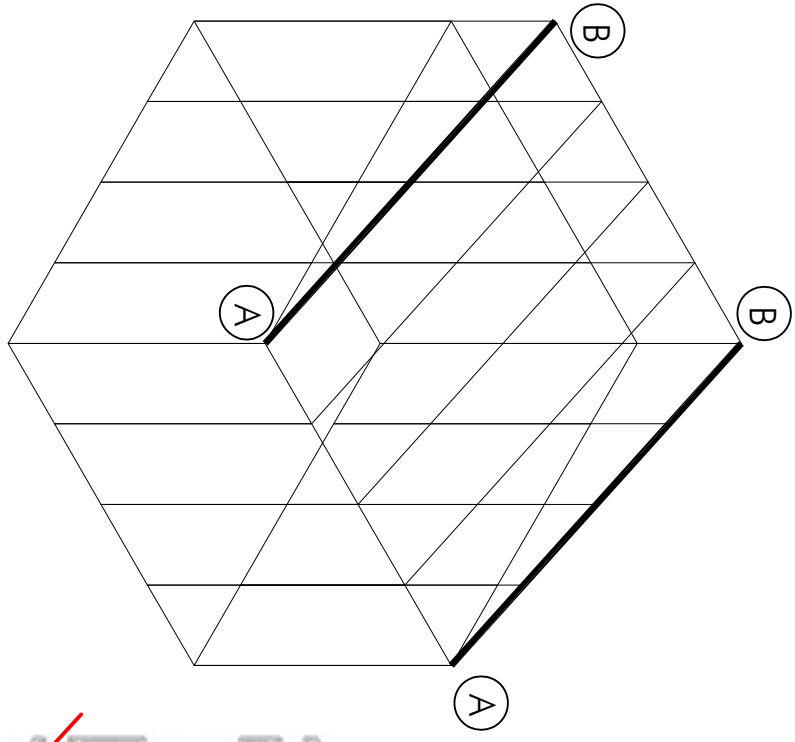
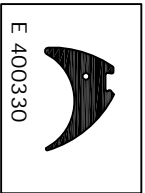

Schuifdeur-Porte Coulissante-Schiebetür-Sliding door
Skydedør-Skyvedør-Skuggväv-Porta scorrevole-Skjutdörr

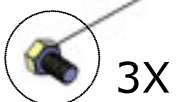
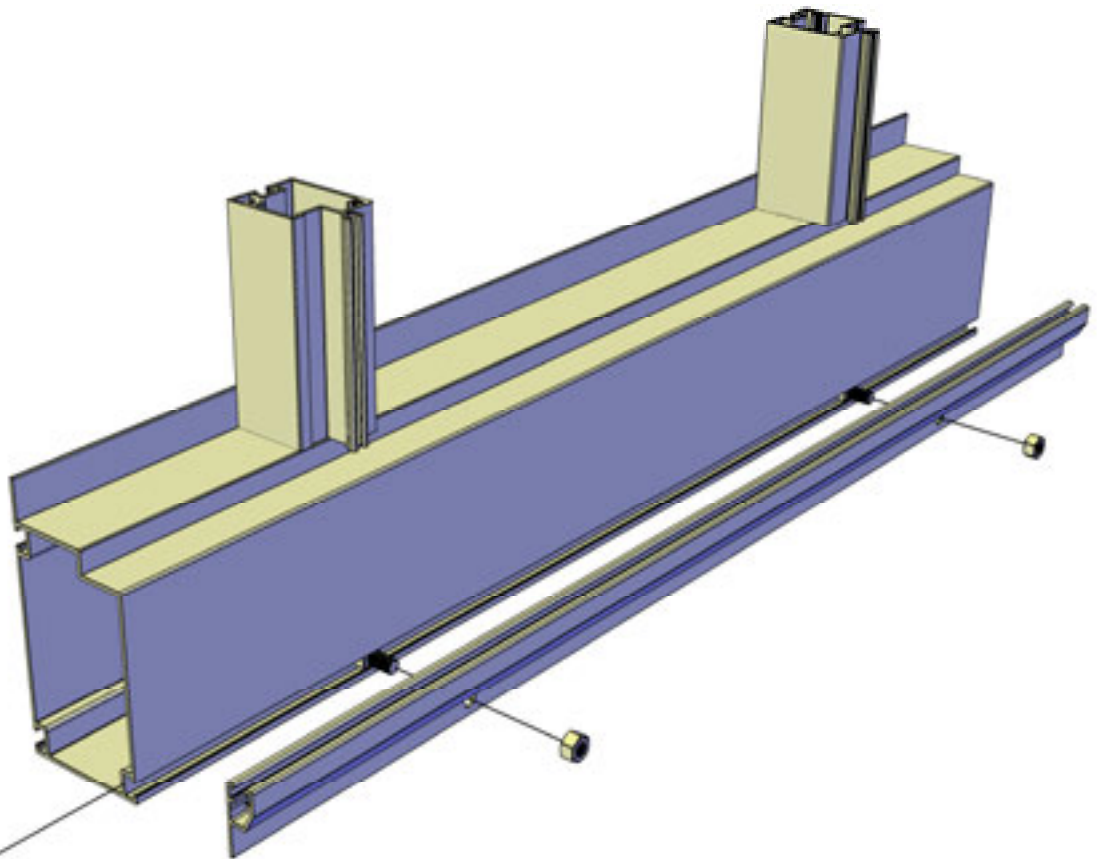
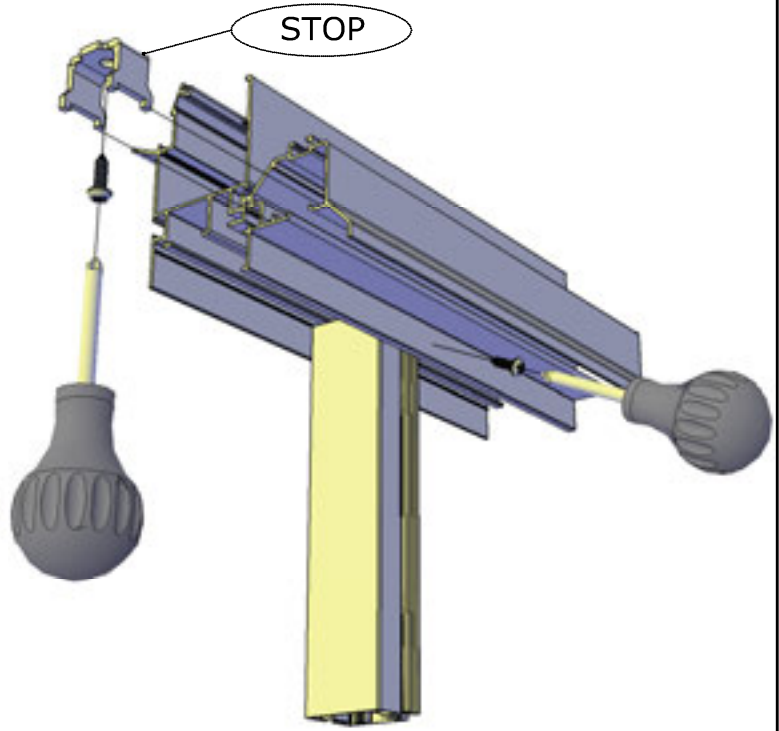
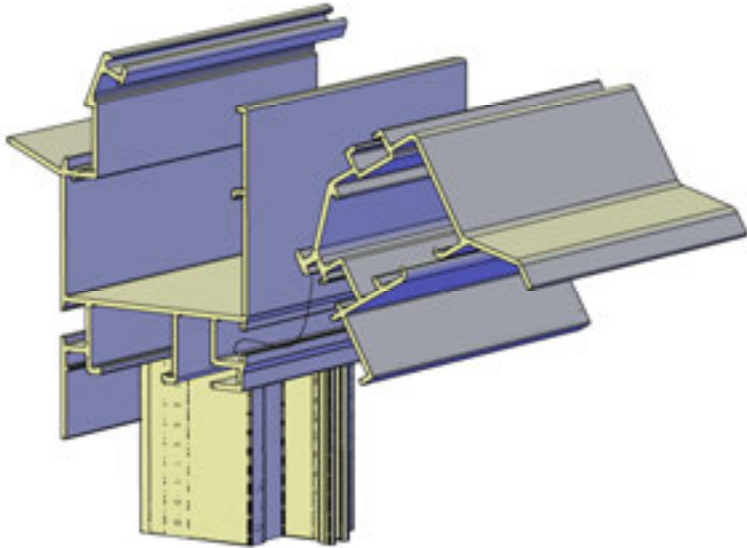
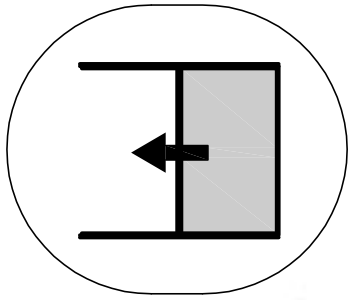

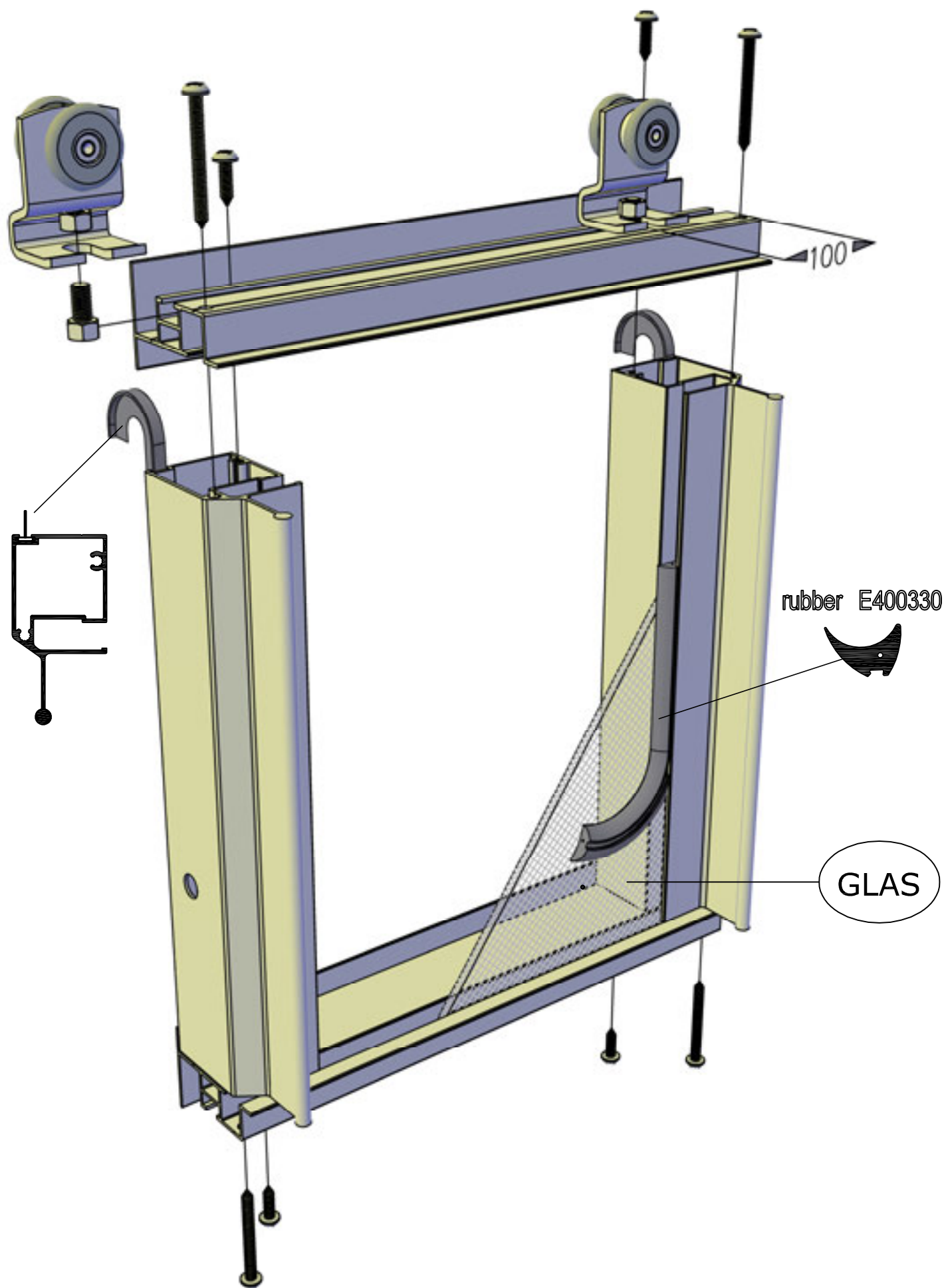

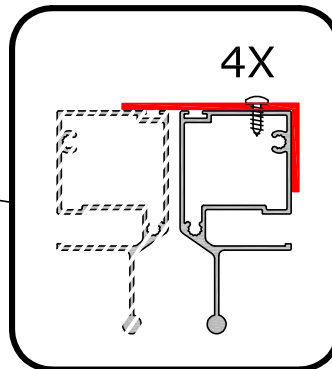
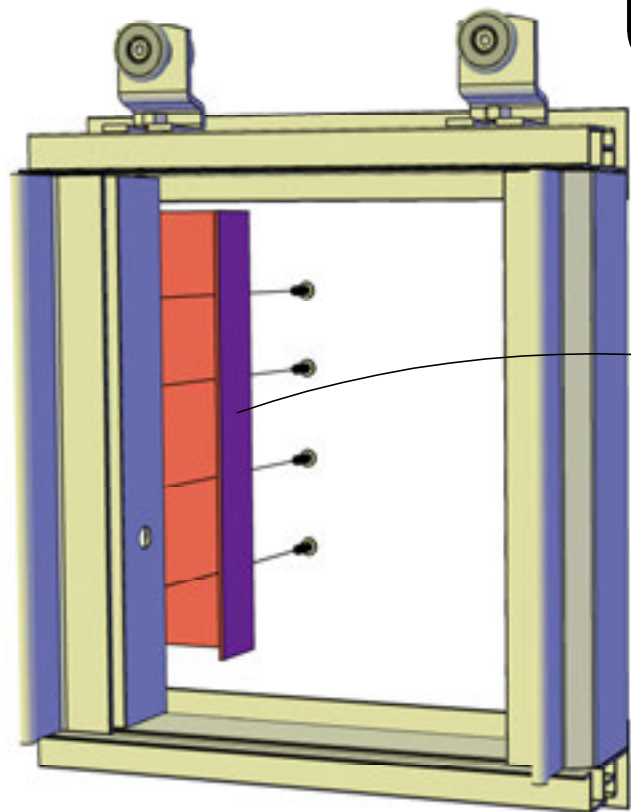
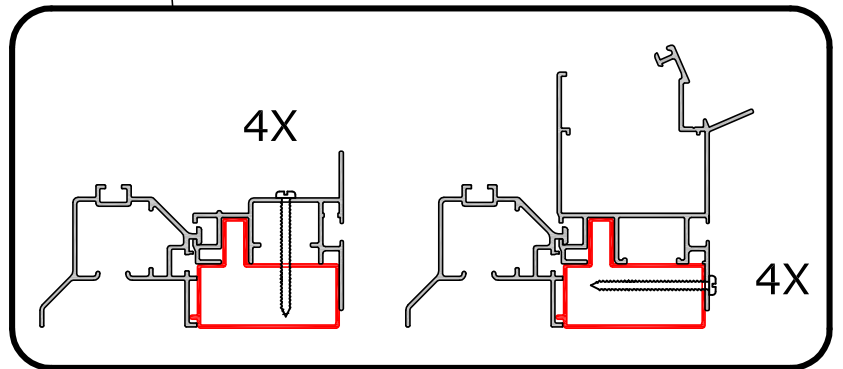
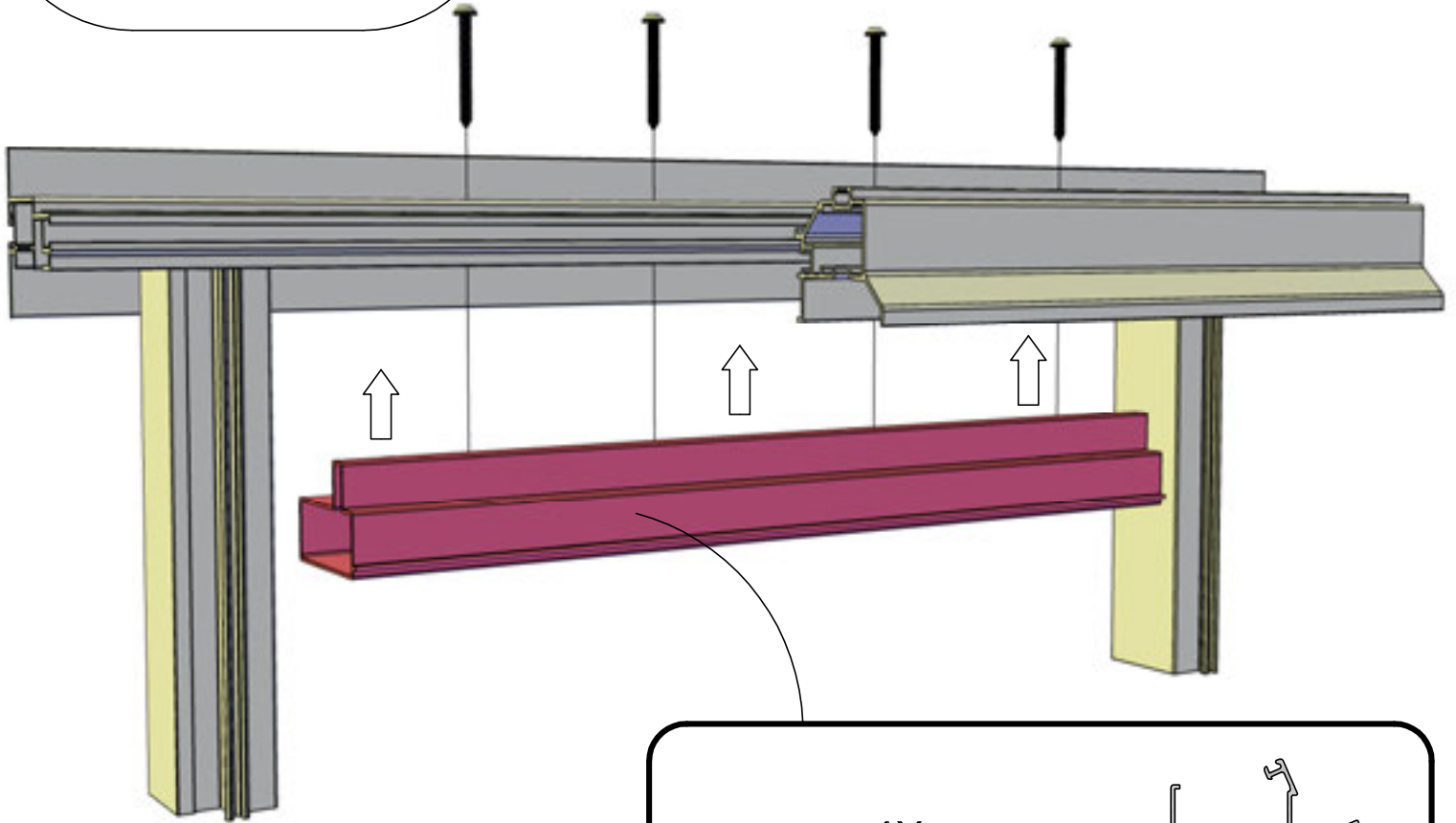
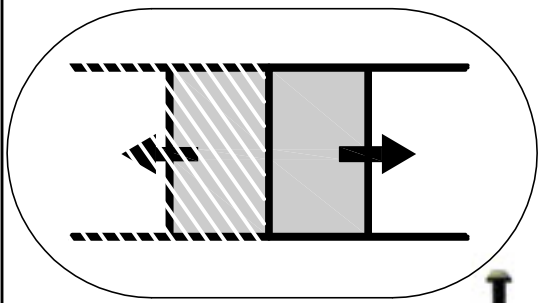

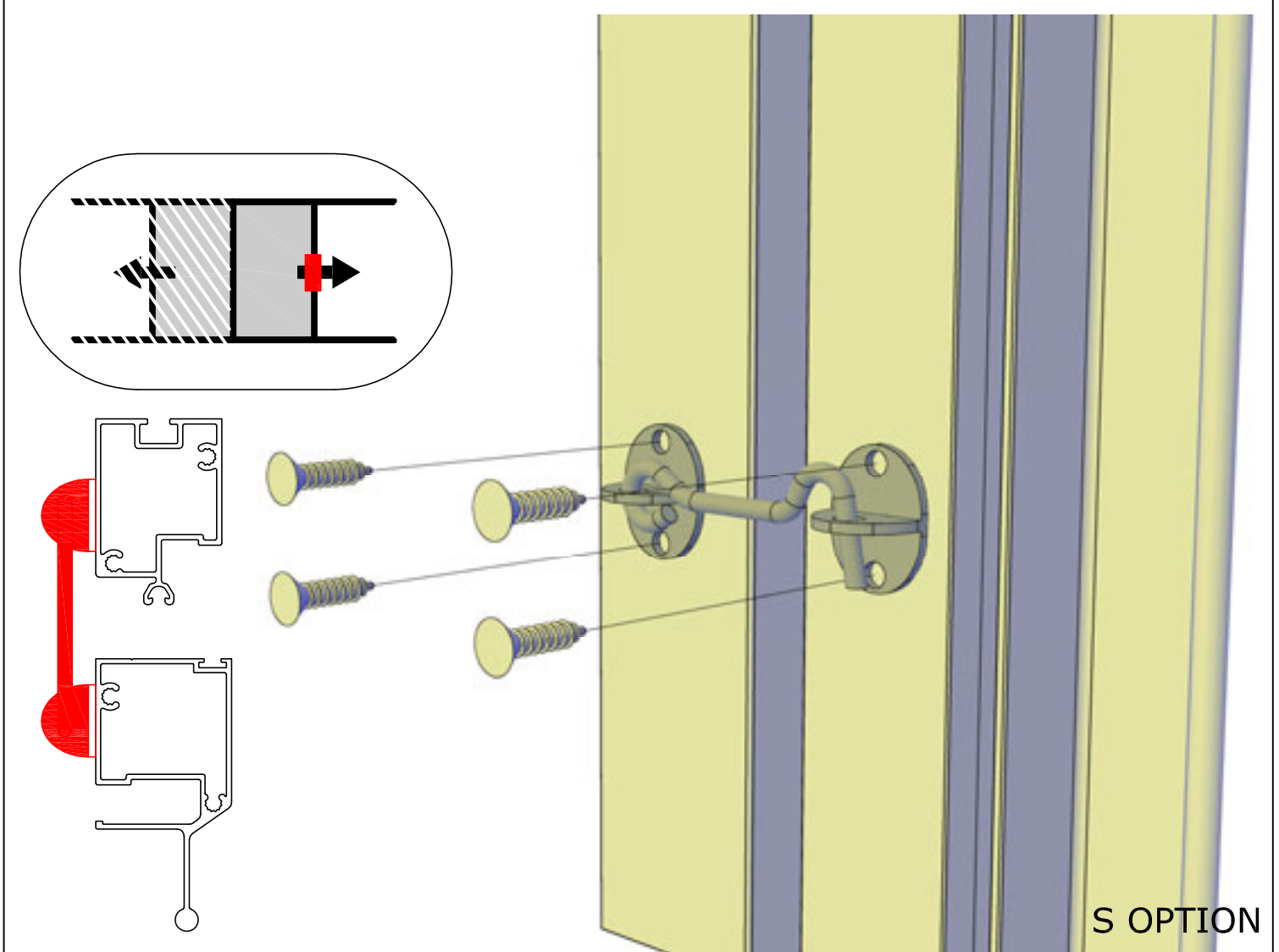
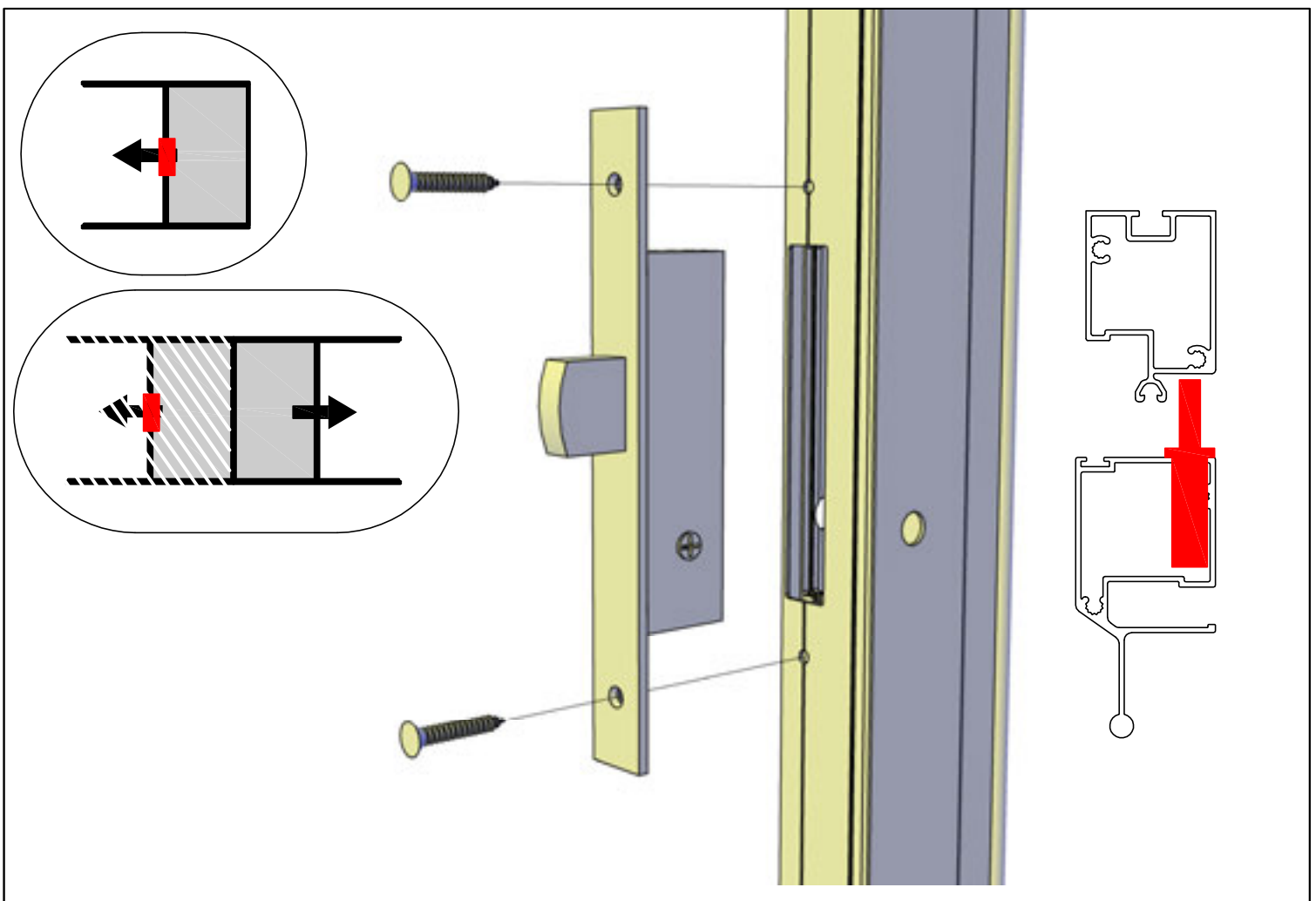

S OPTION

Lammelenraam - Lamellenfenster - Louvre vent
Lamellfenster - Louvre

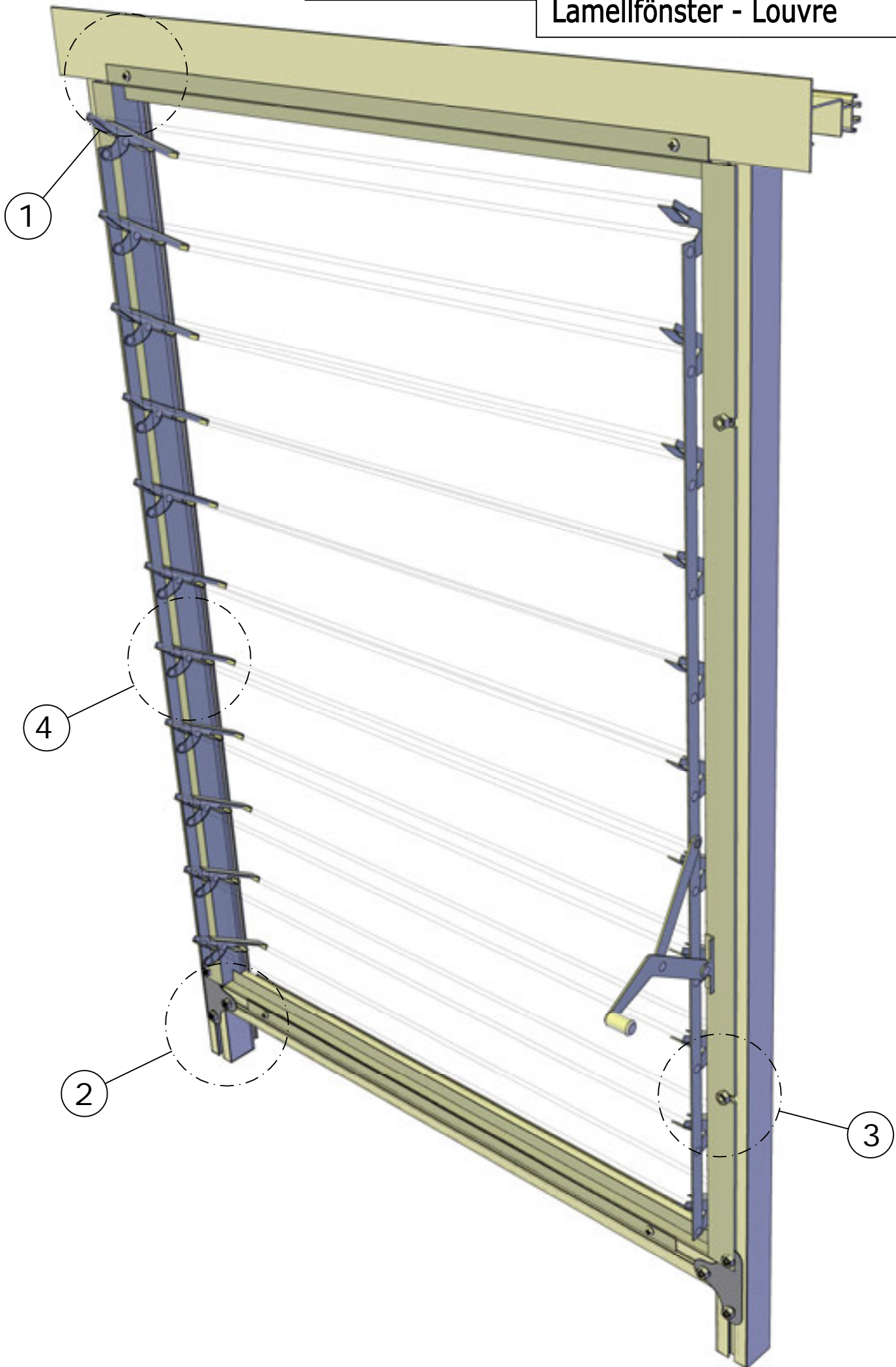

Lammelenraam - Lamellenfenster - Louvre vent - Lamellfenster - Louvre

①

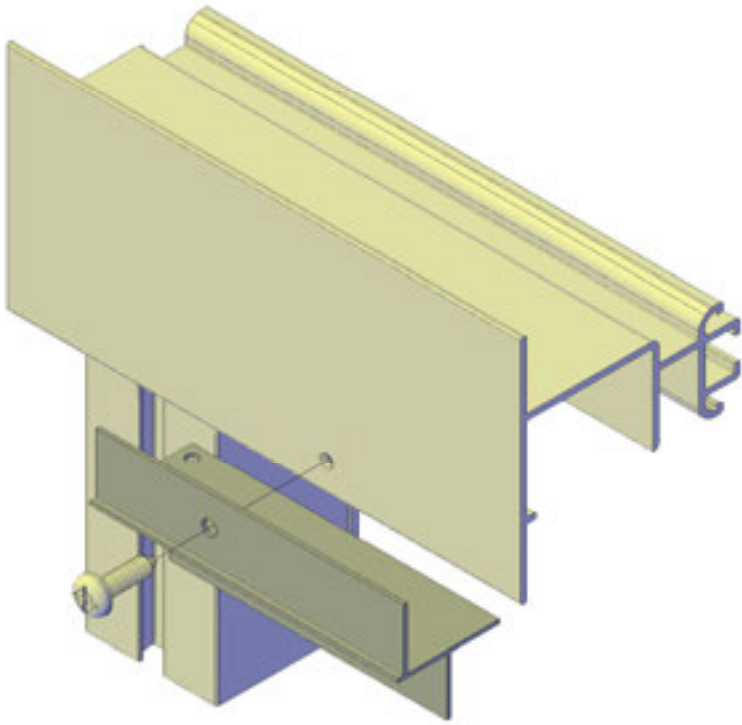

②

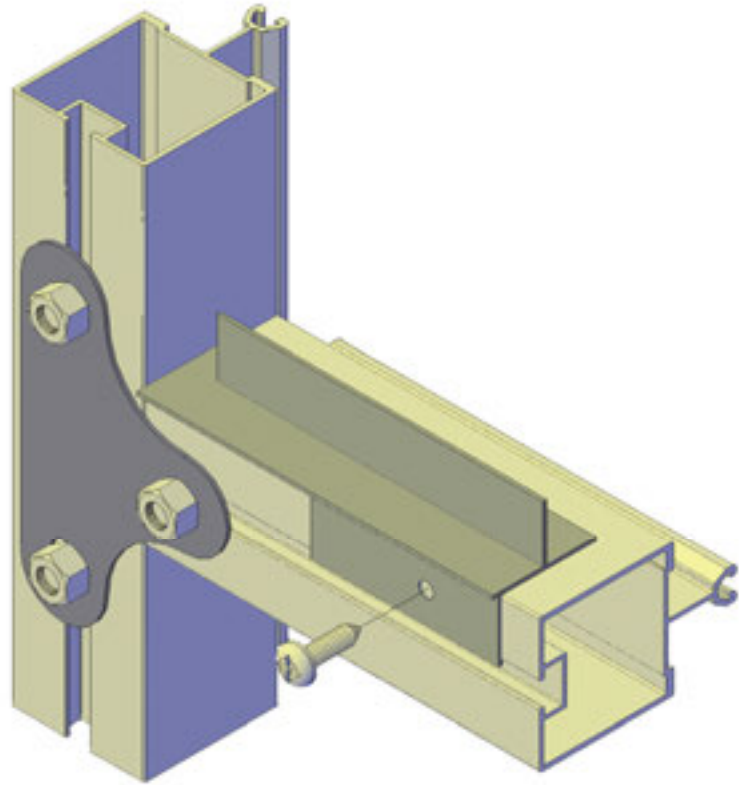

③

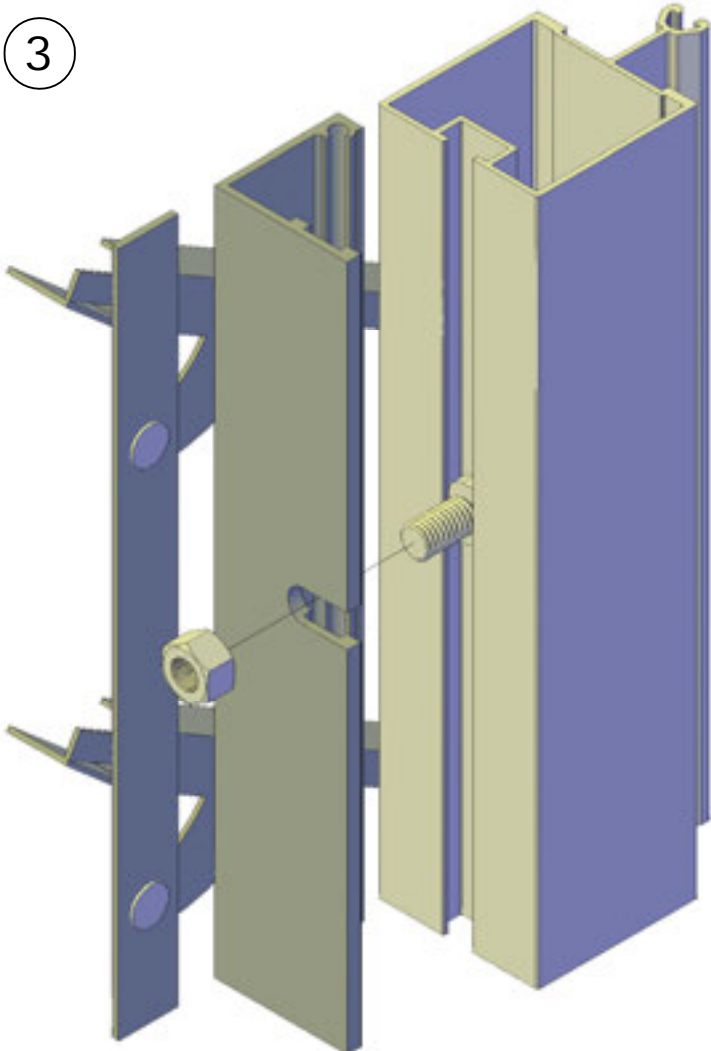

④

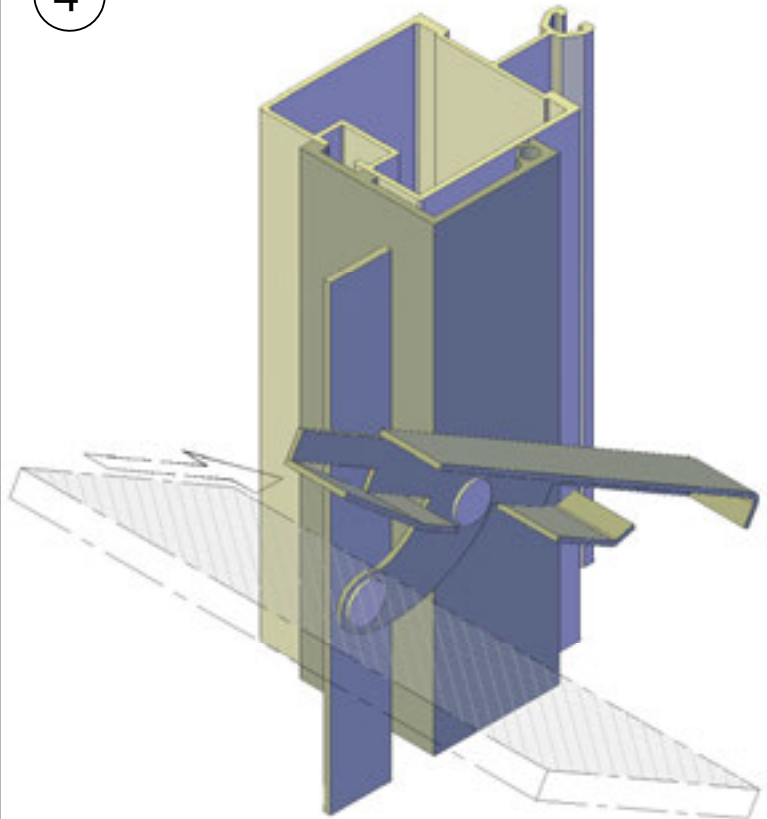

Dakraam-Lucarne-Dachfenster-Roofwindow-Tagvindue
Takluke-Takfönster-Finestra del tetto

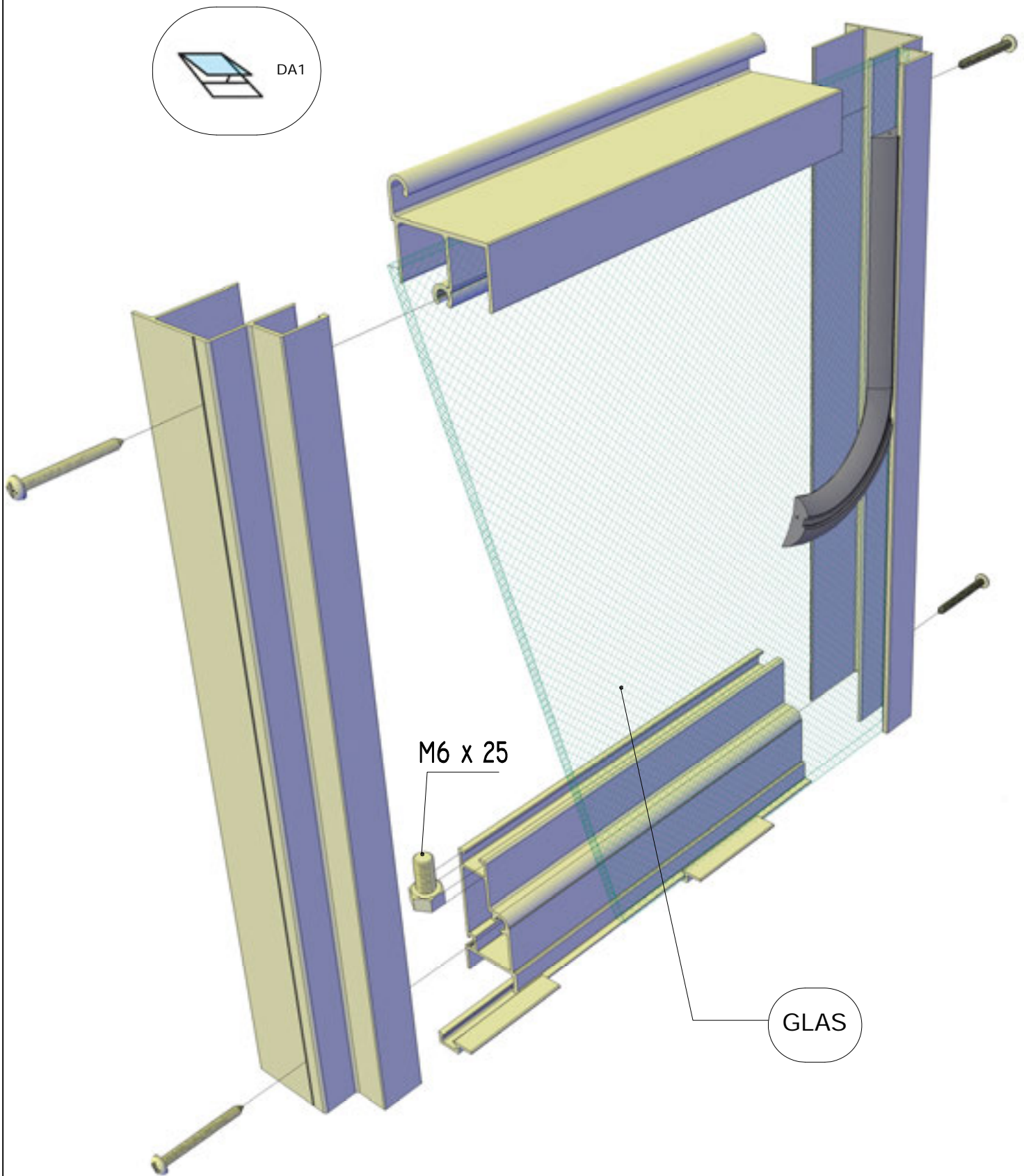

RUBBER E400330

DA1

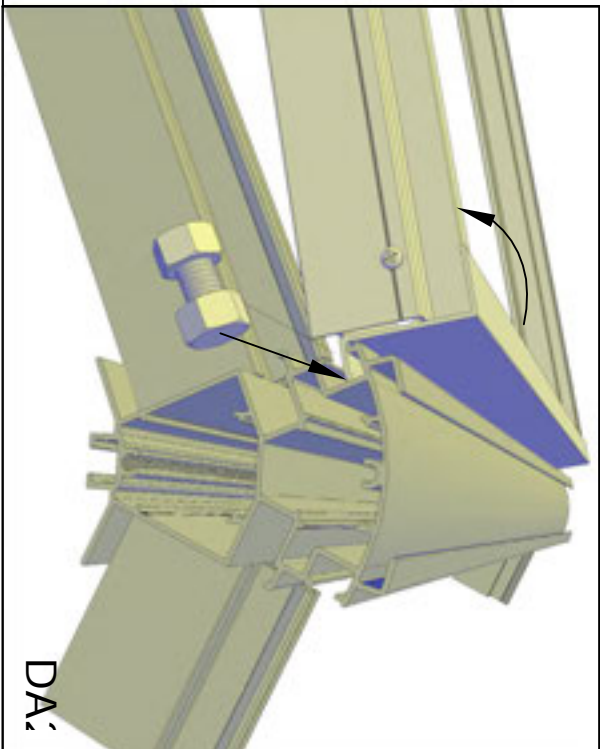
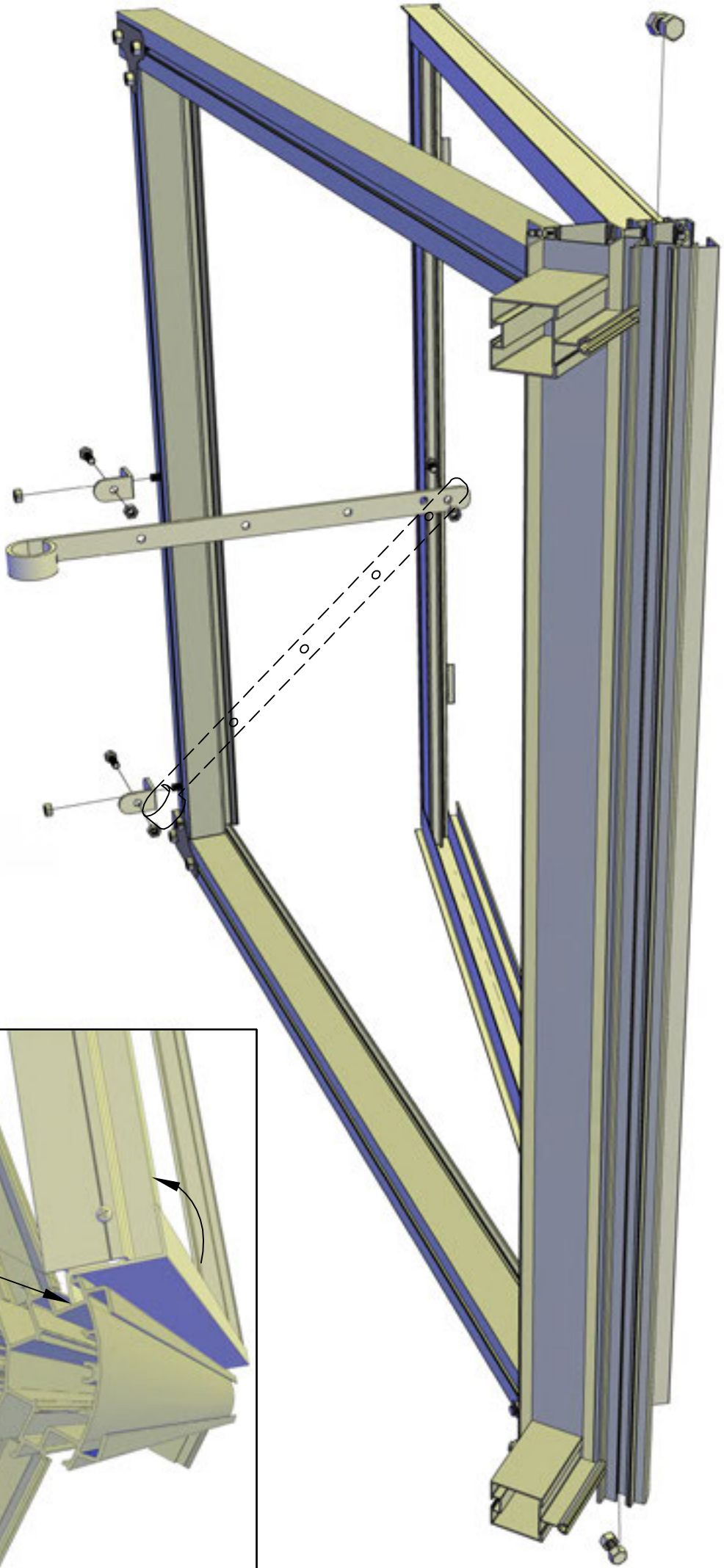

DA:

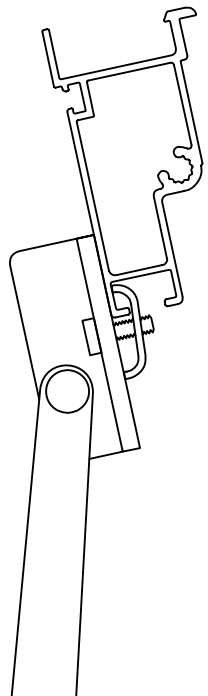
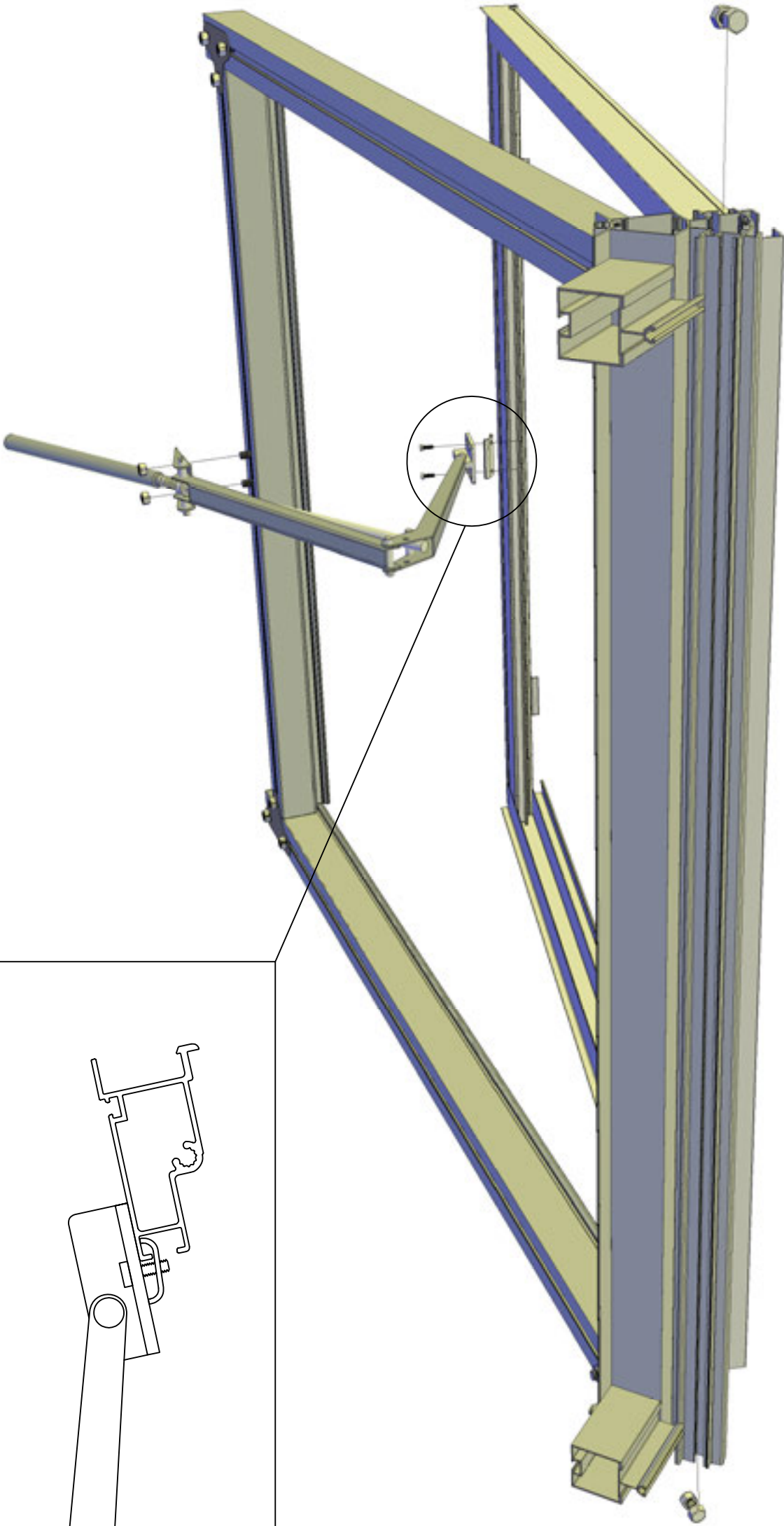

DA:

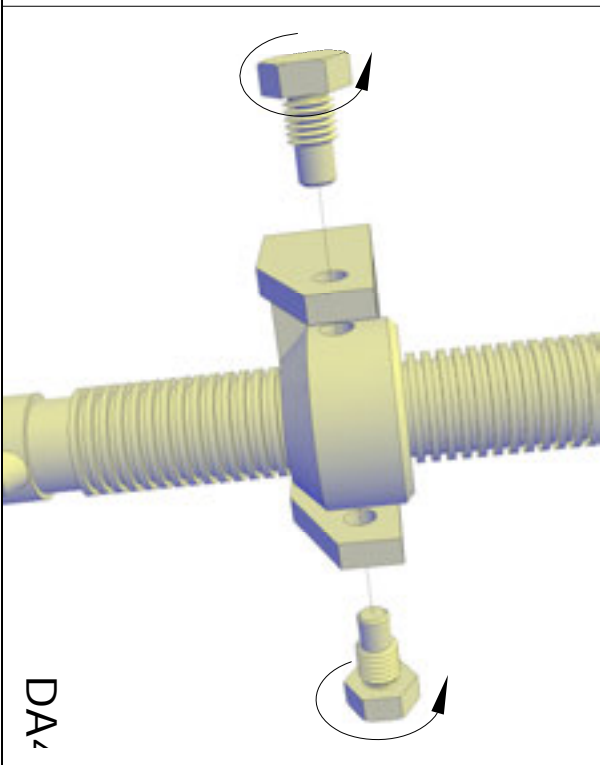
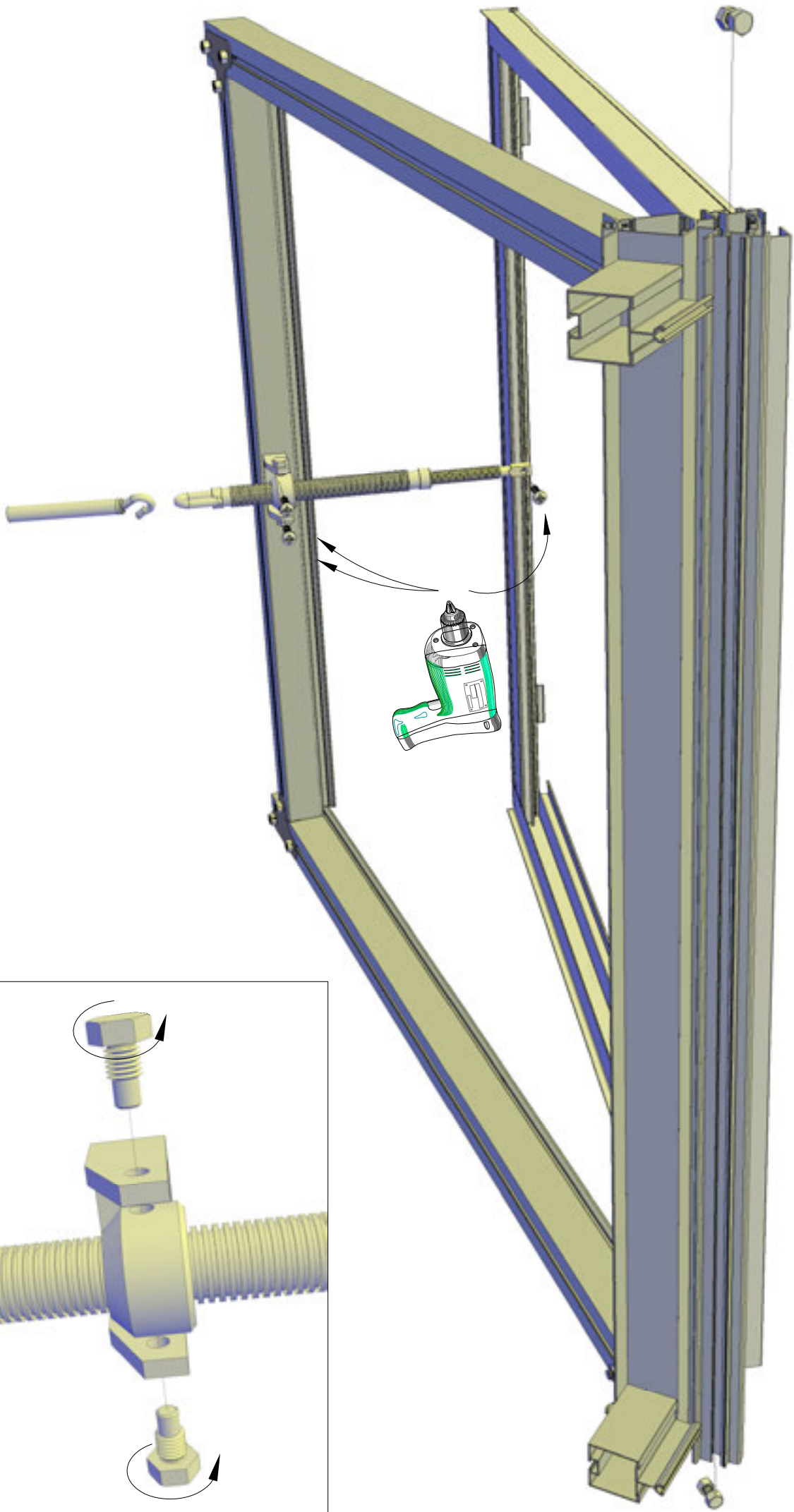

DA2

Draaideur - Porte Tournante - Drehtür - Turning door
Hengslet dør - Slagdörr - Porta a battente

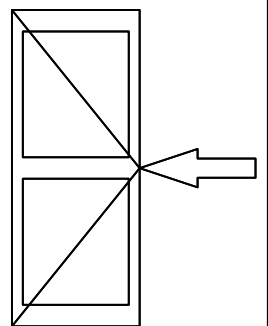
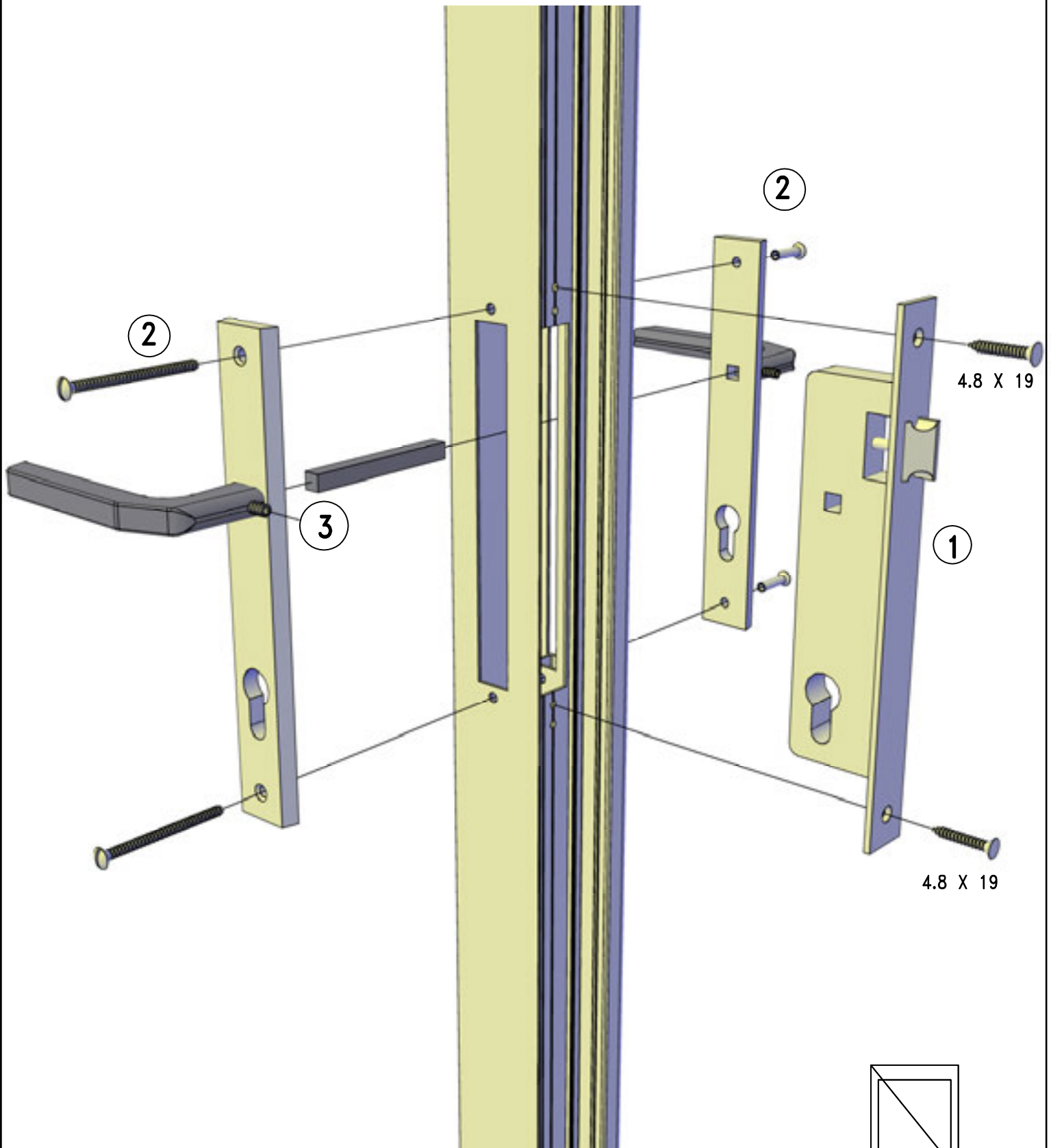

DD1

22 X

4.8 X 70

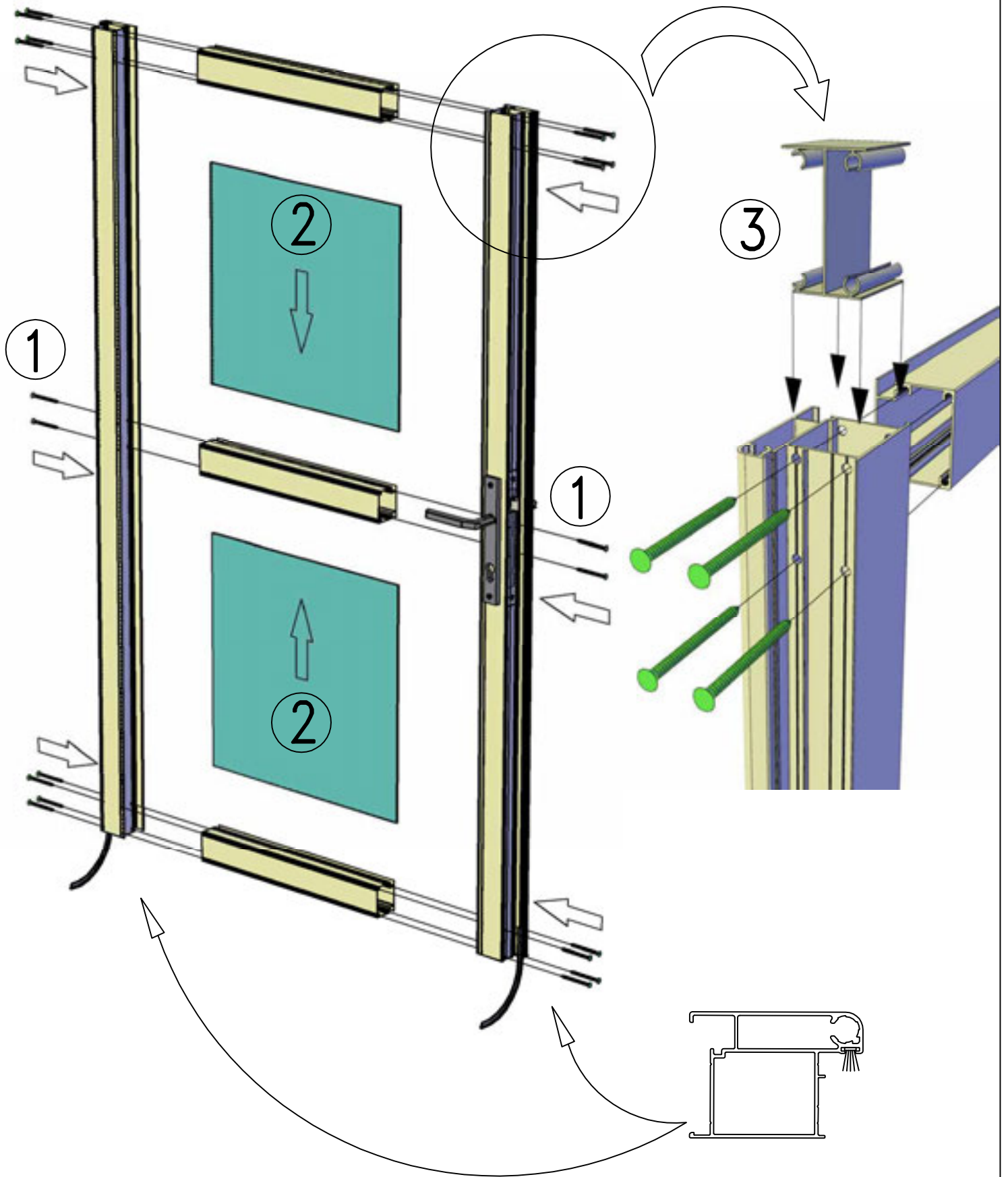

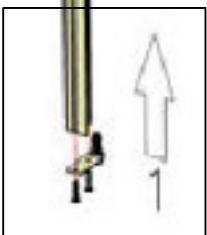
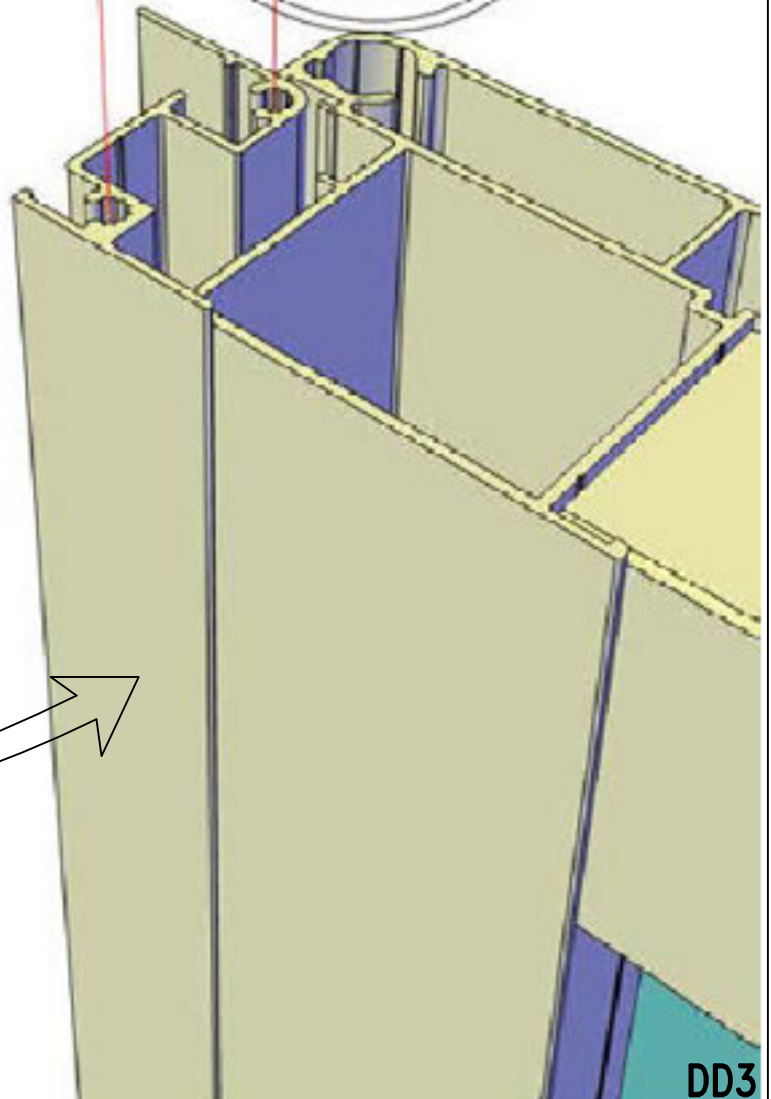
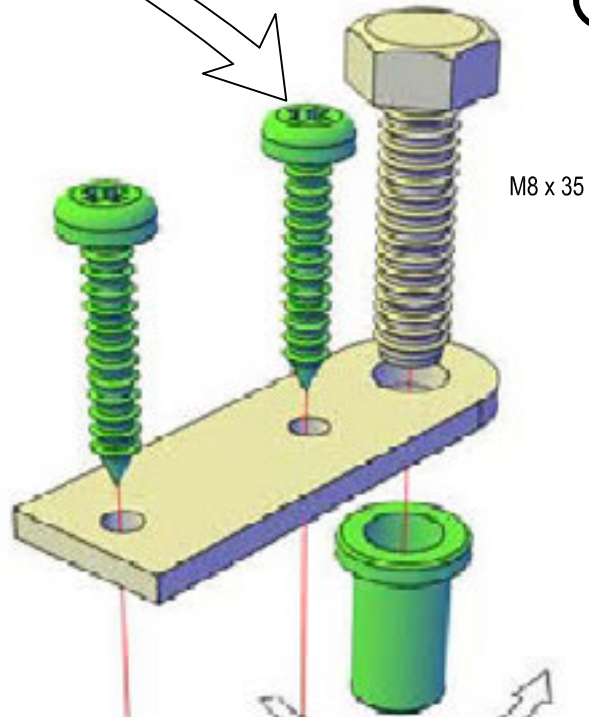
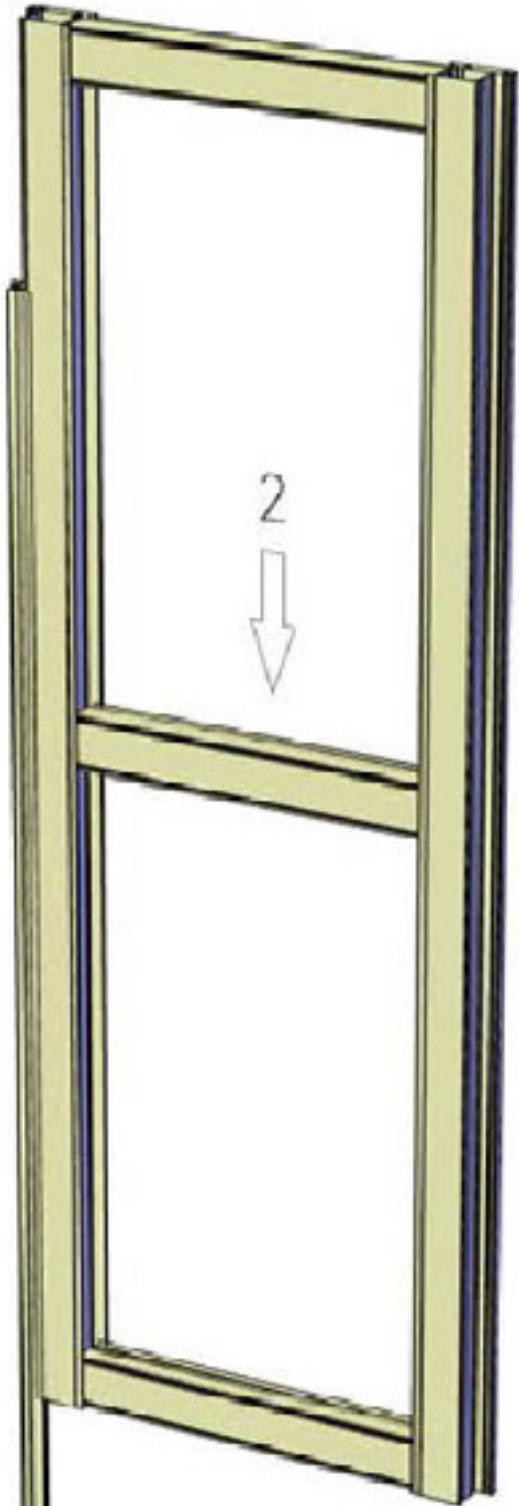
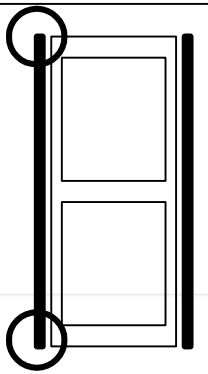
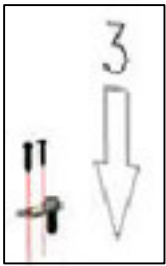

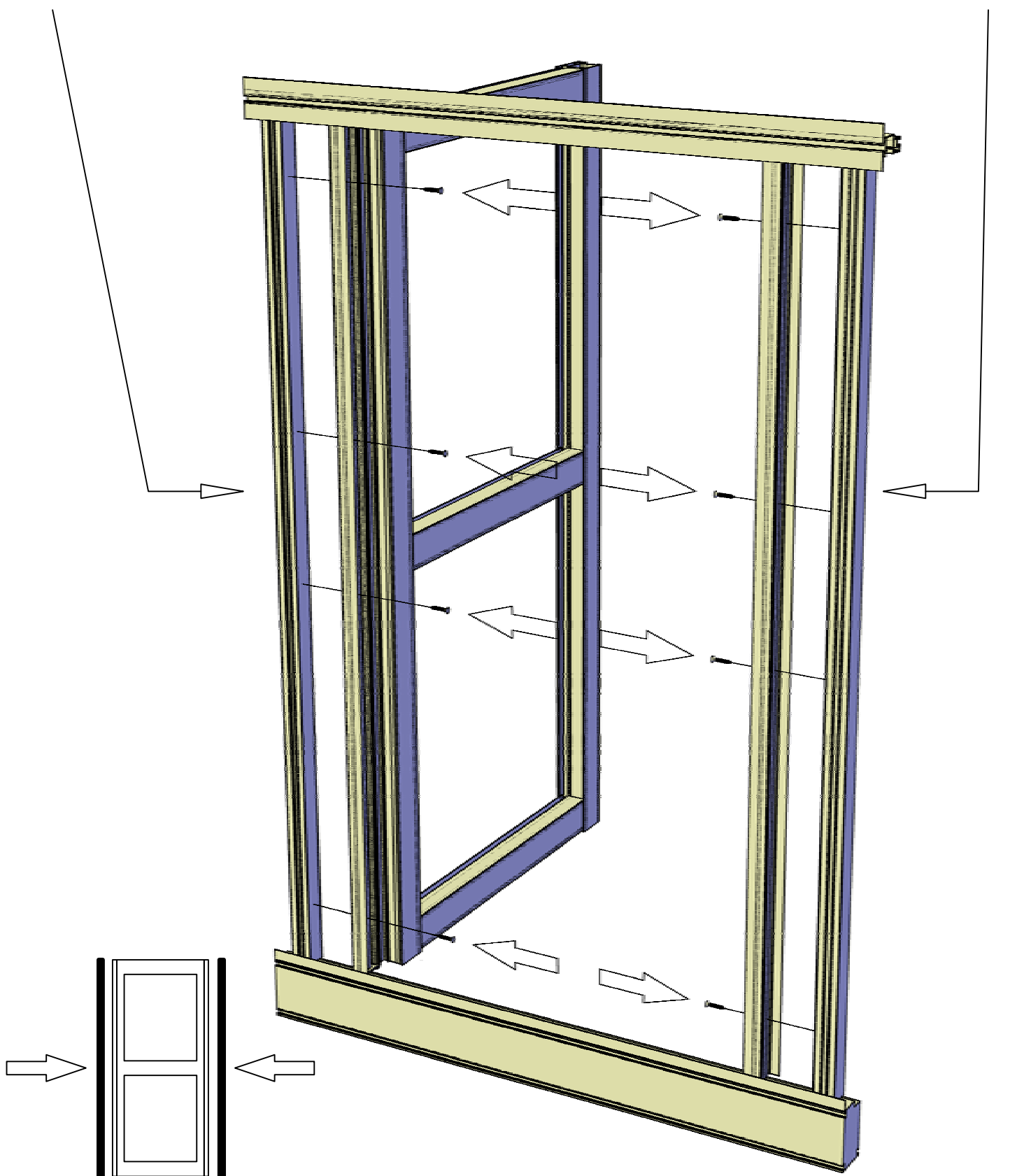
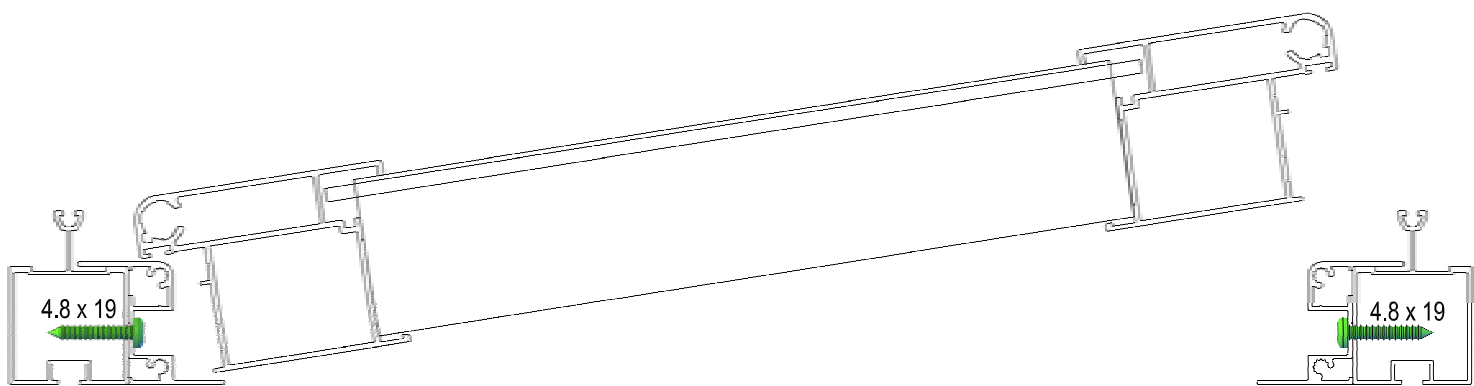

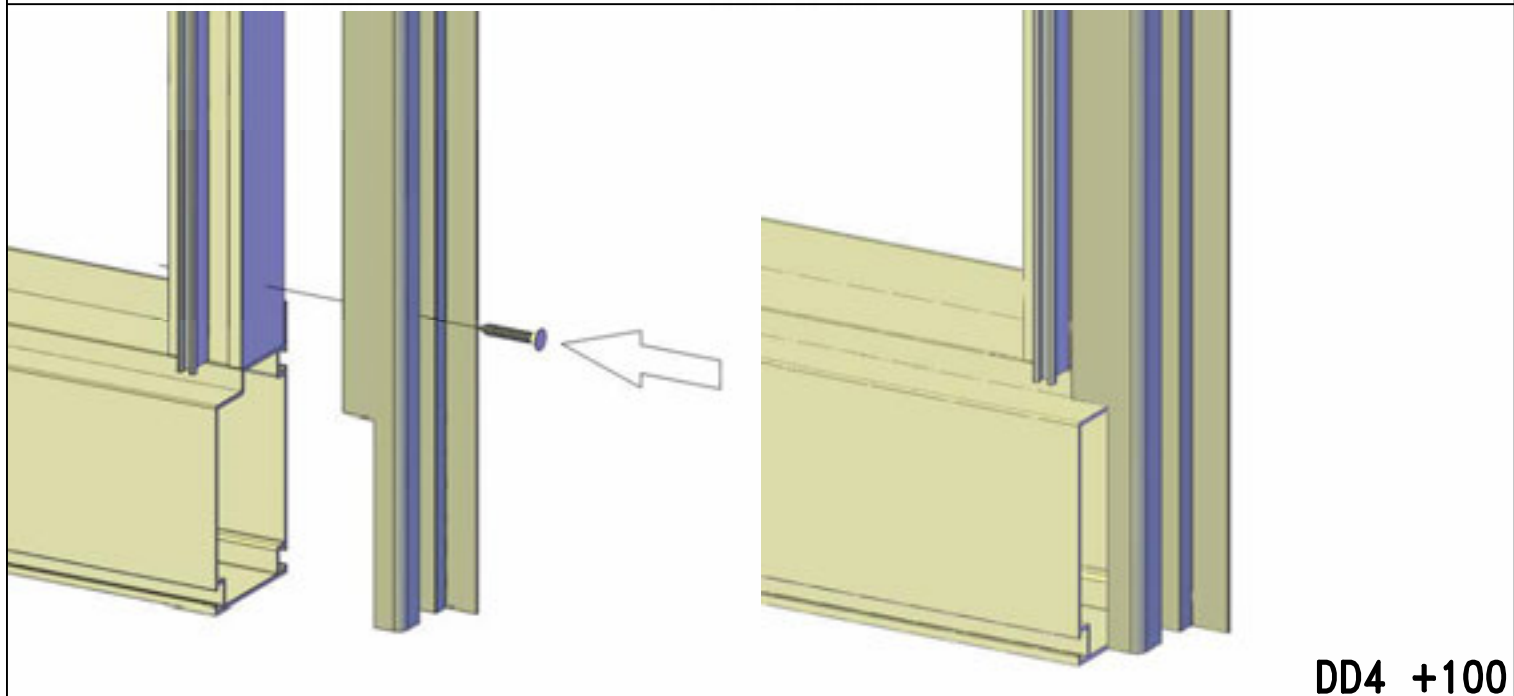
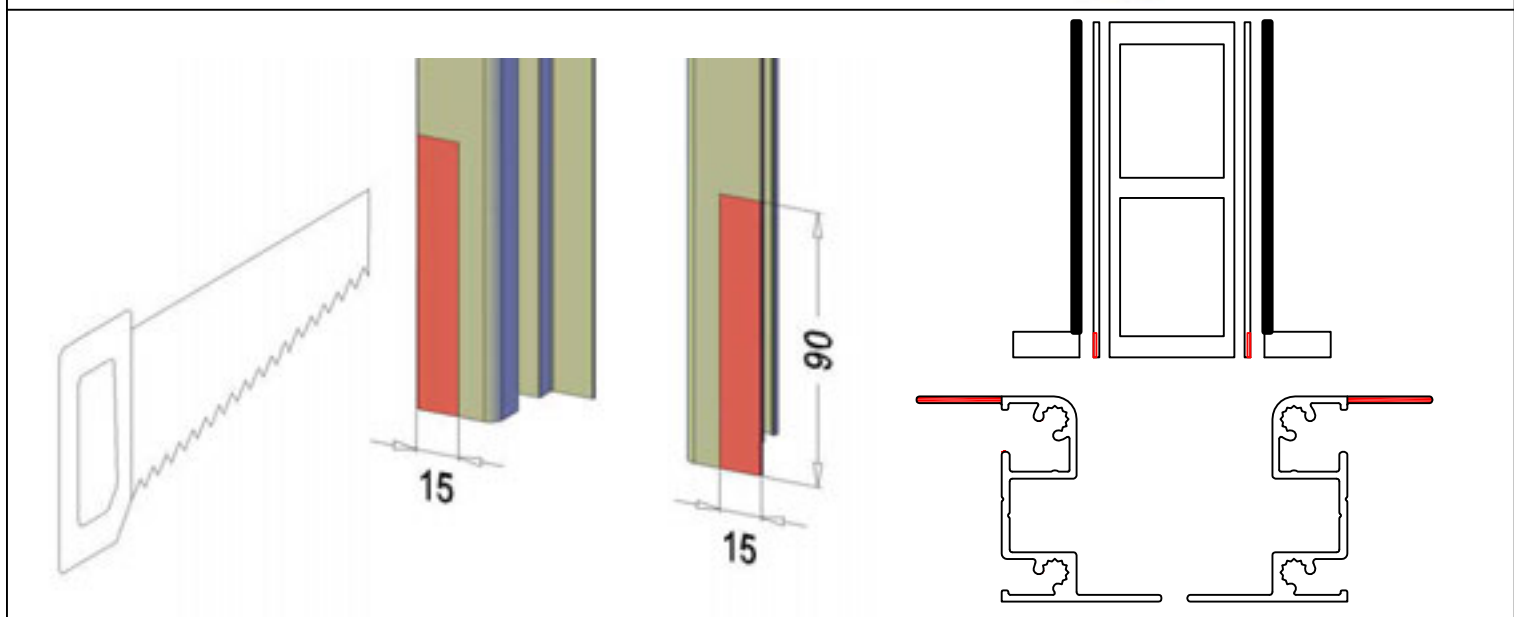
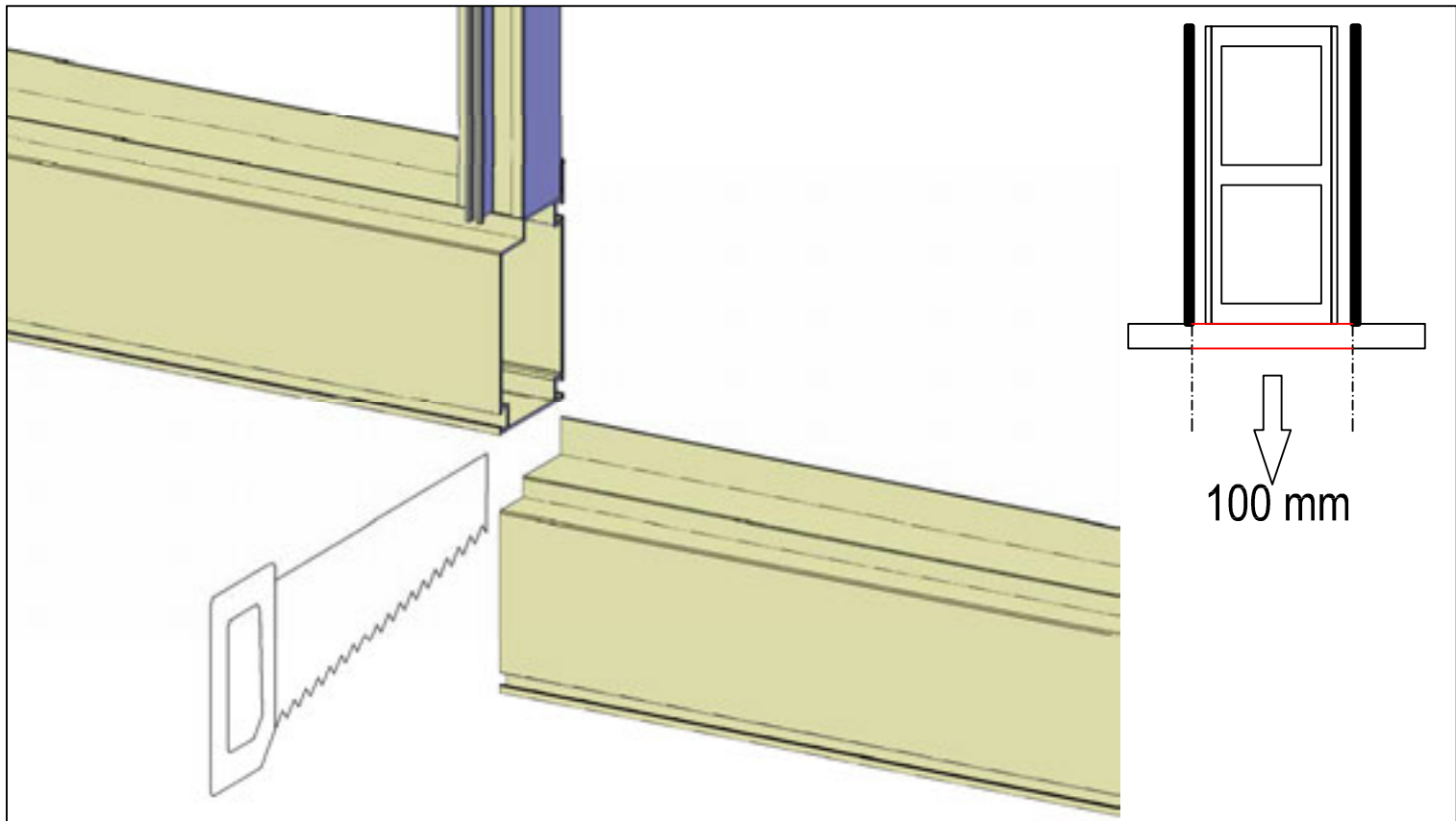

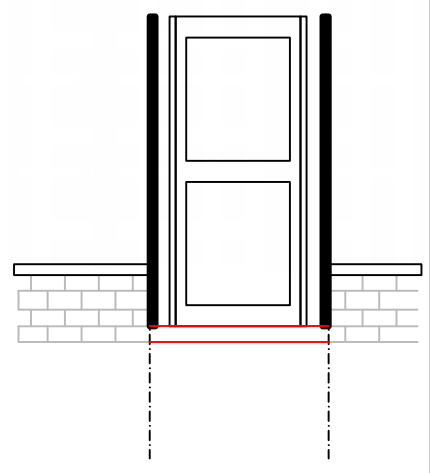
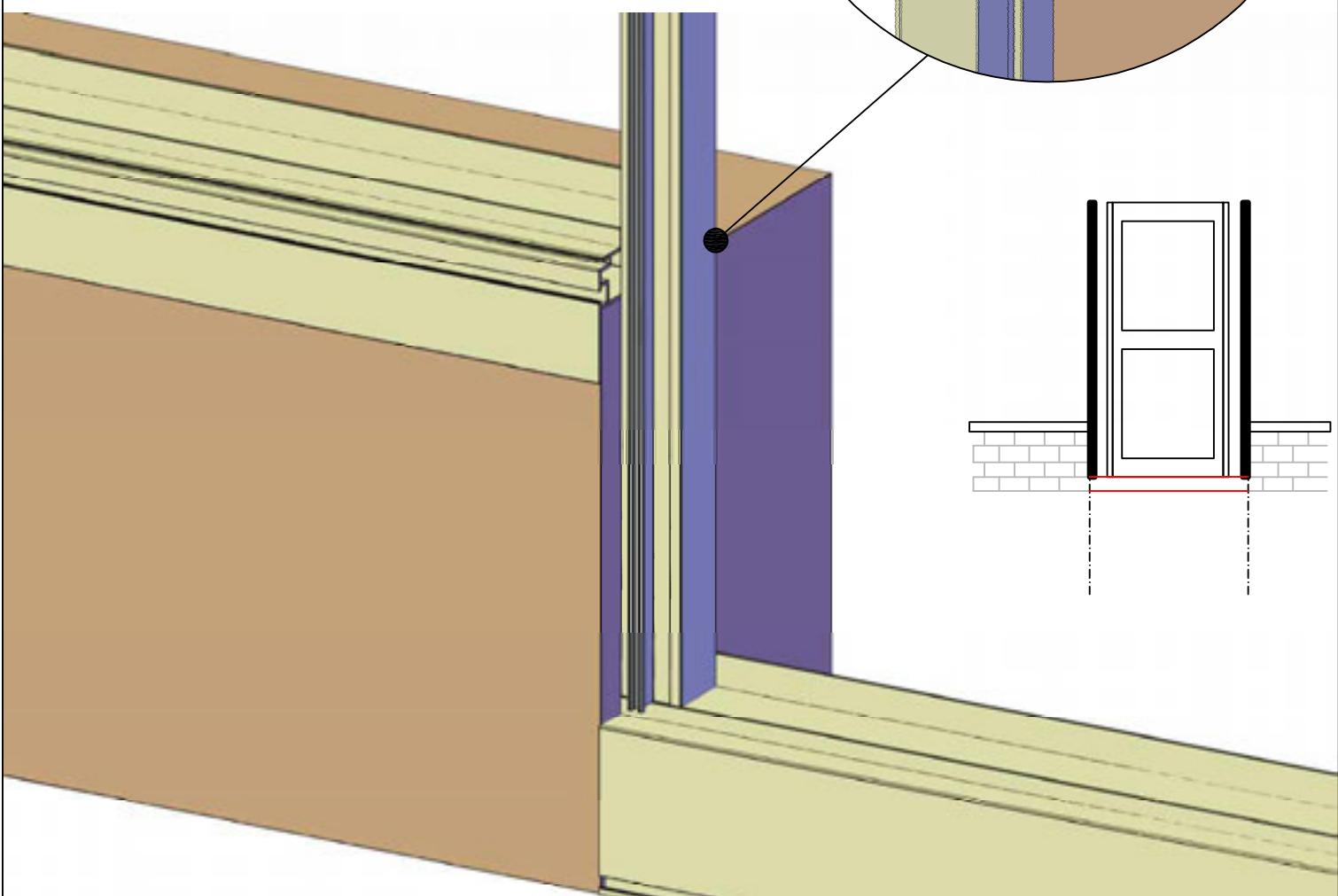
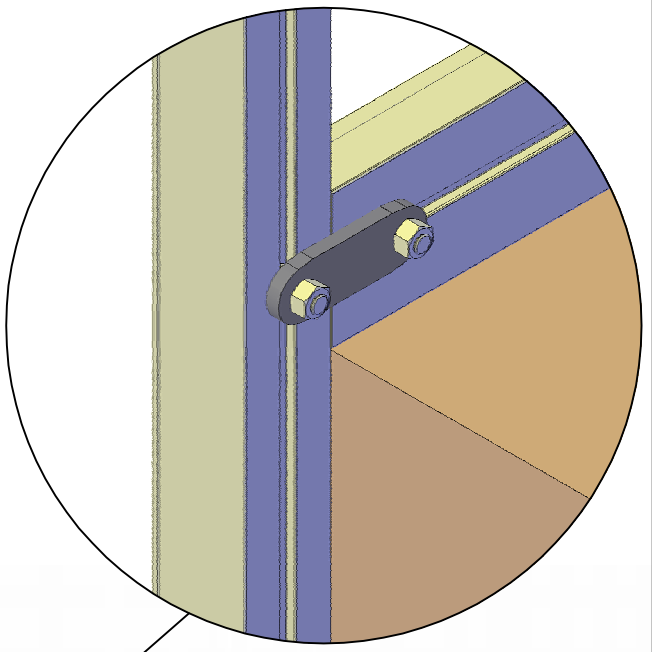
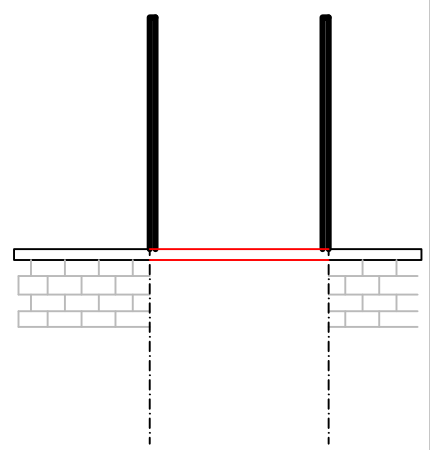
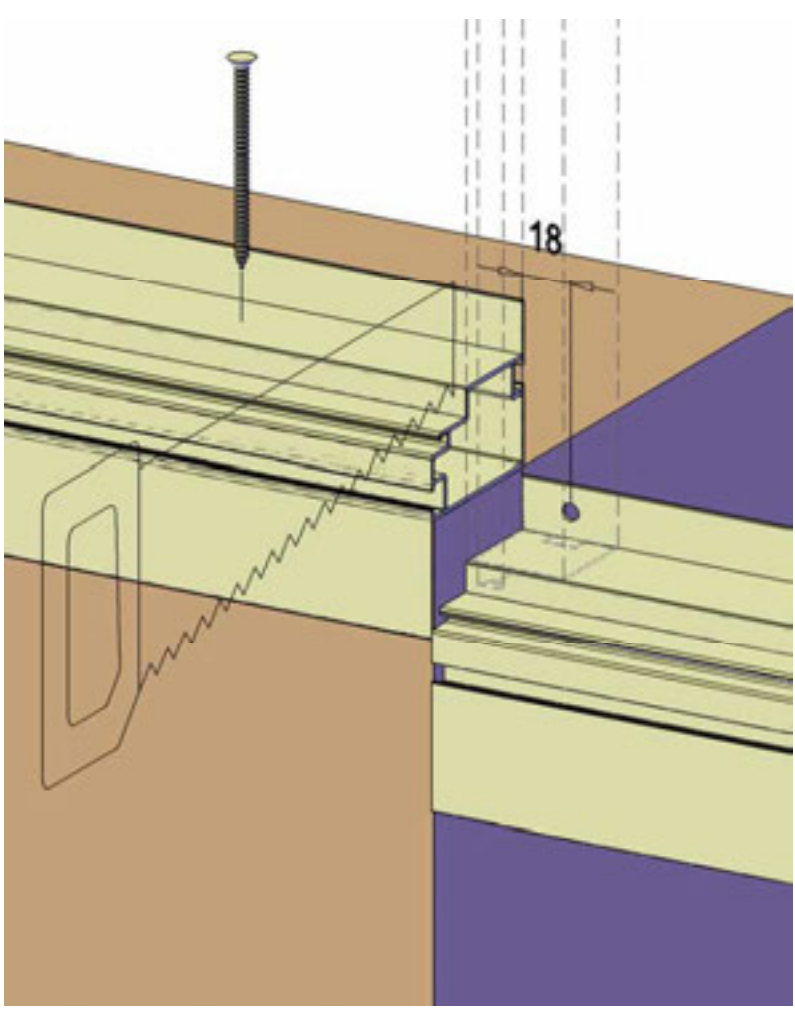

DD4 WALL

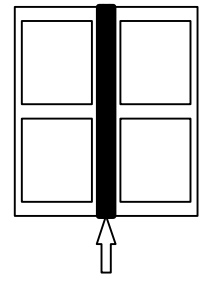
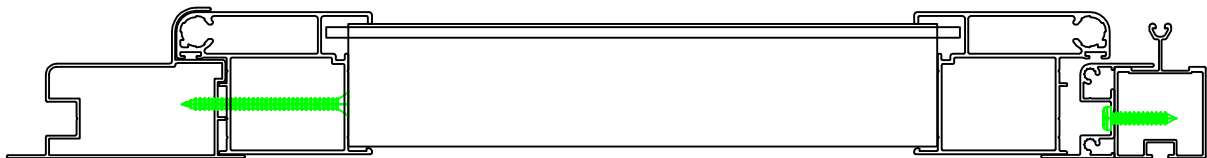

24 X

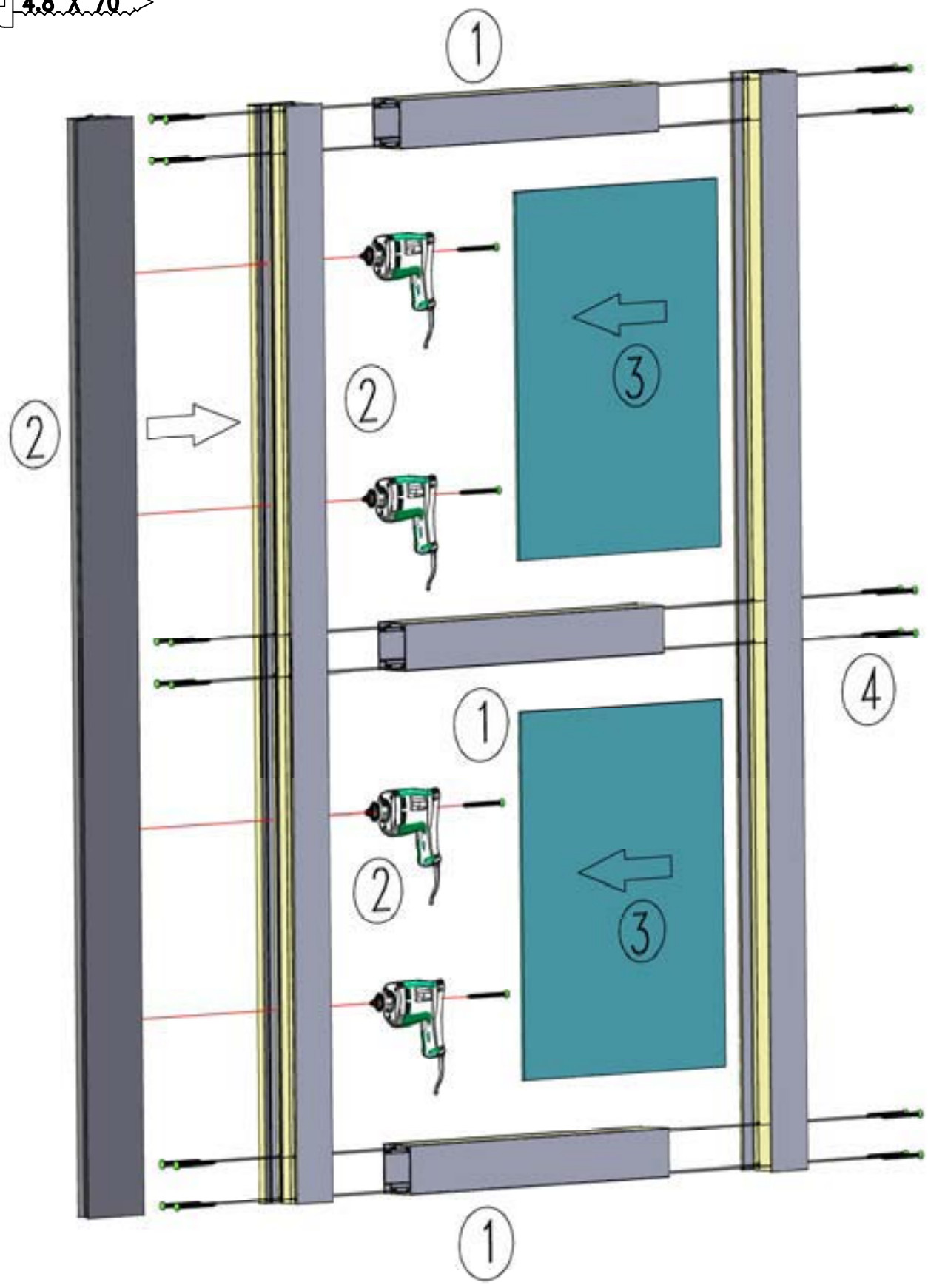

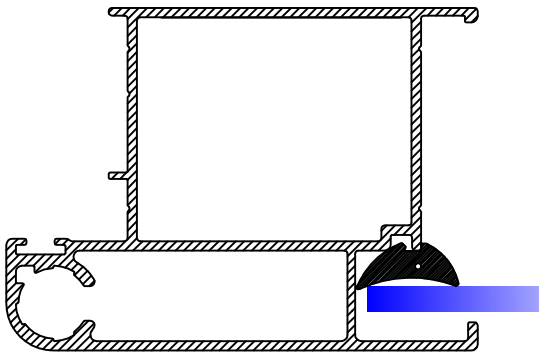
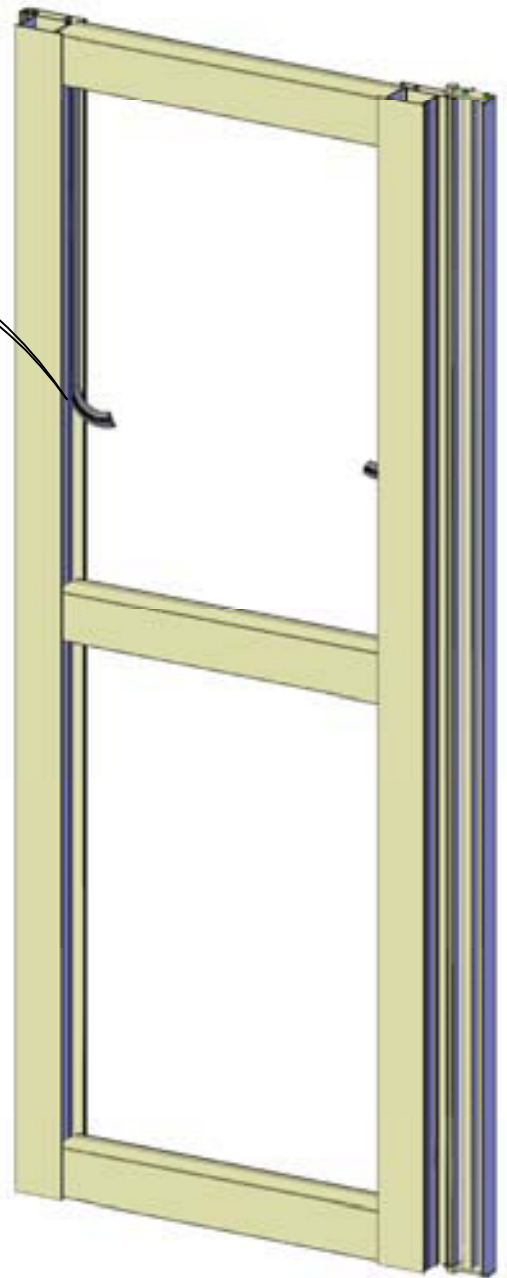
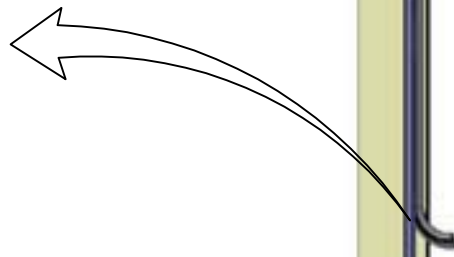

! OPTION !

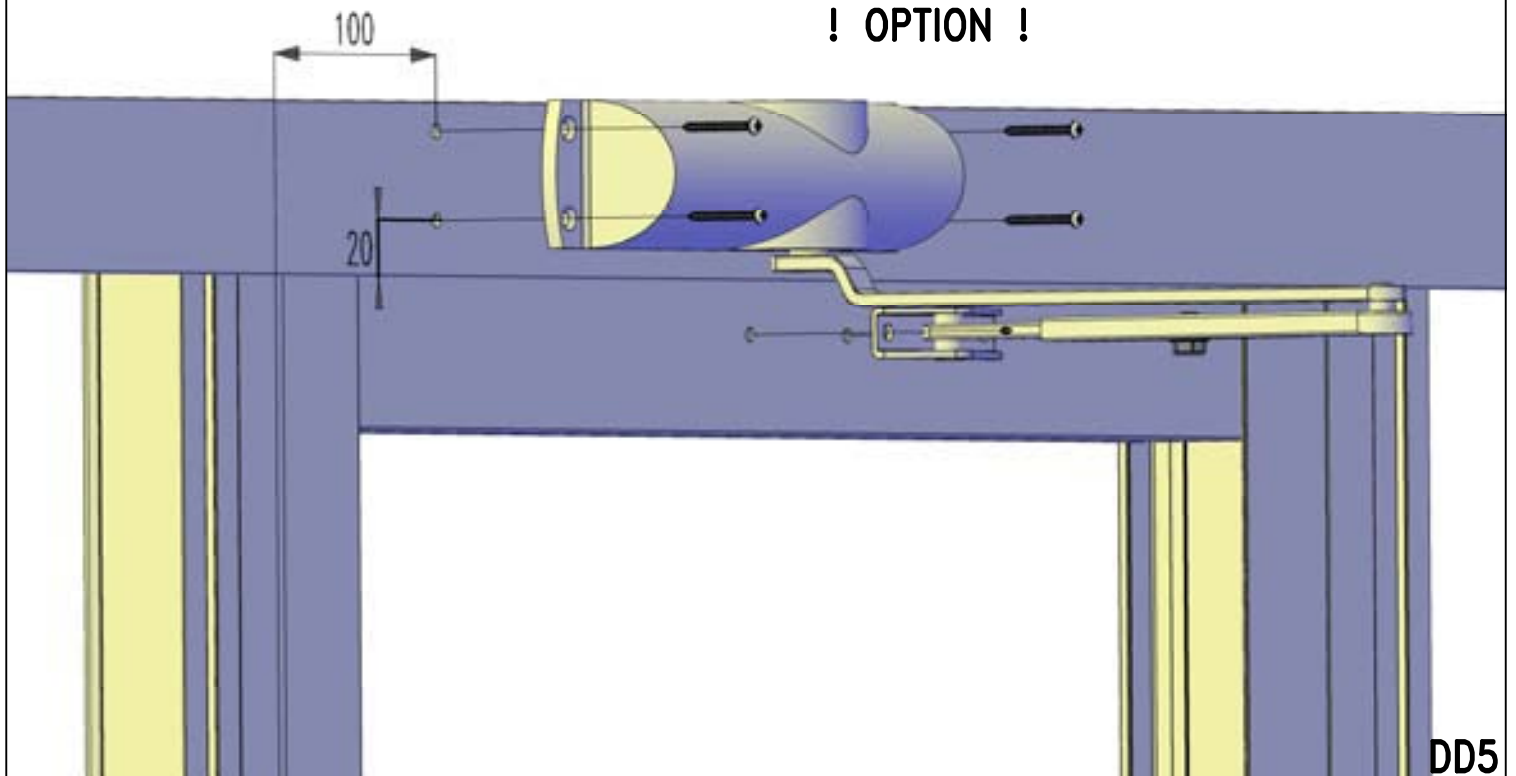

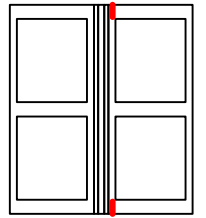
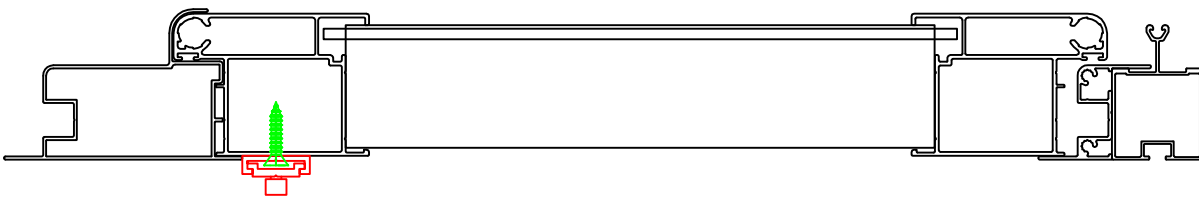

4 X

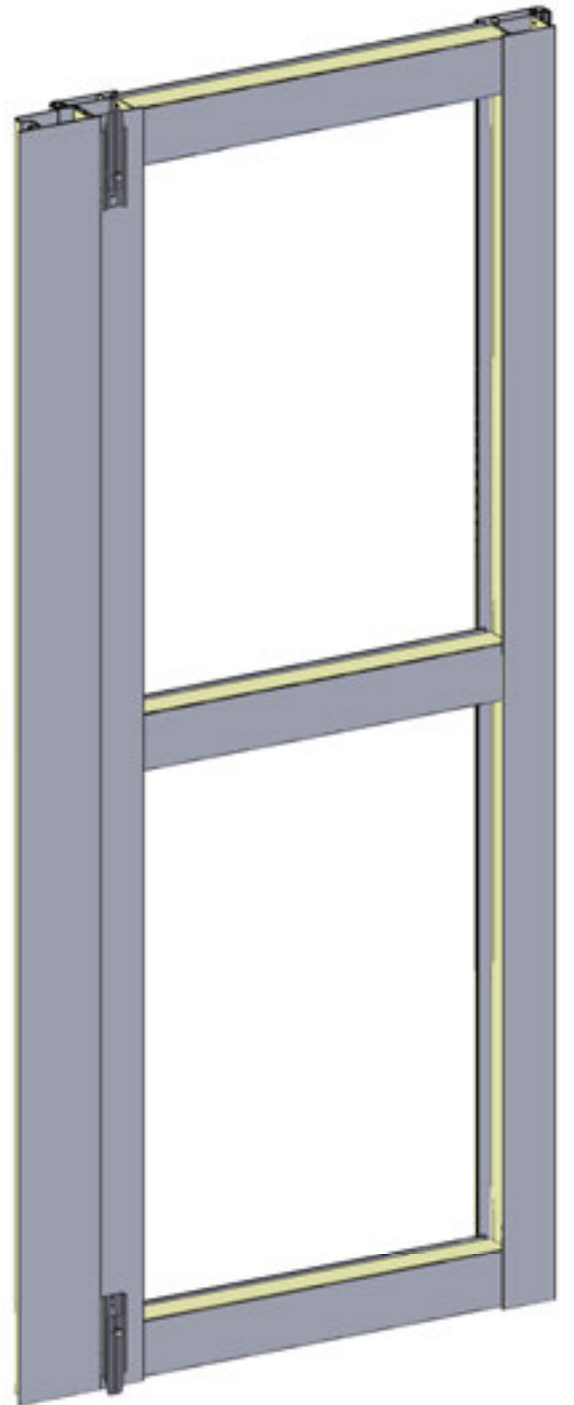
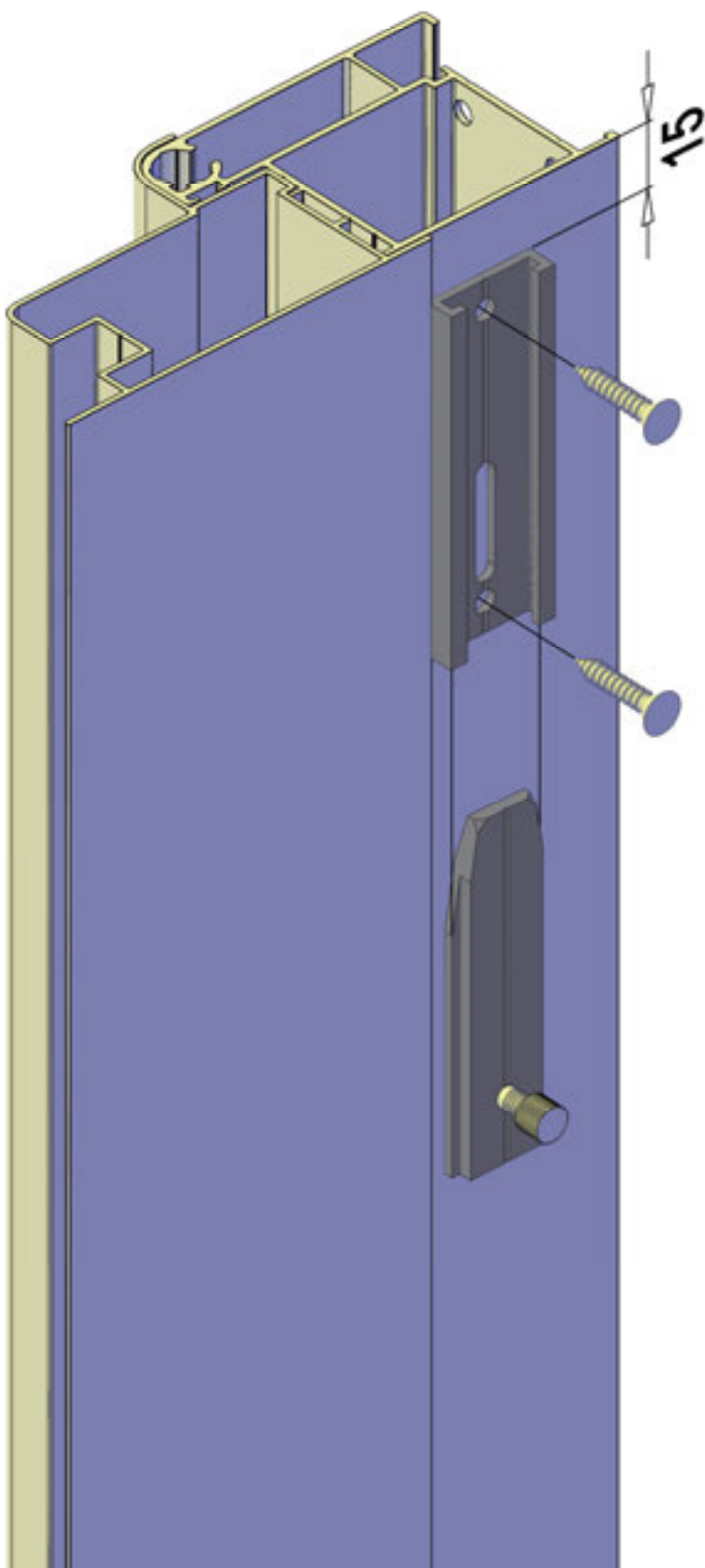

Uitzetraam - Fenêtre Basculante - Aufstellfenster - Tophangwindow
Tophængslet vindu - Topphængt sidofönster - Finestra basculante - Tophægt vindue

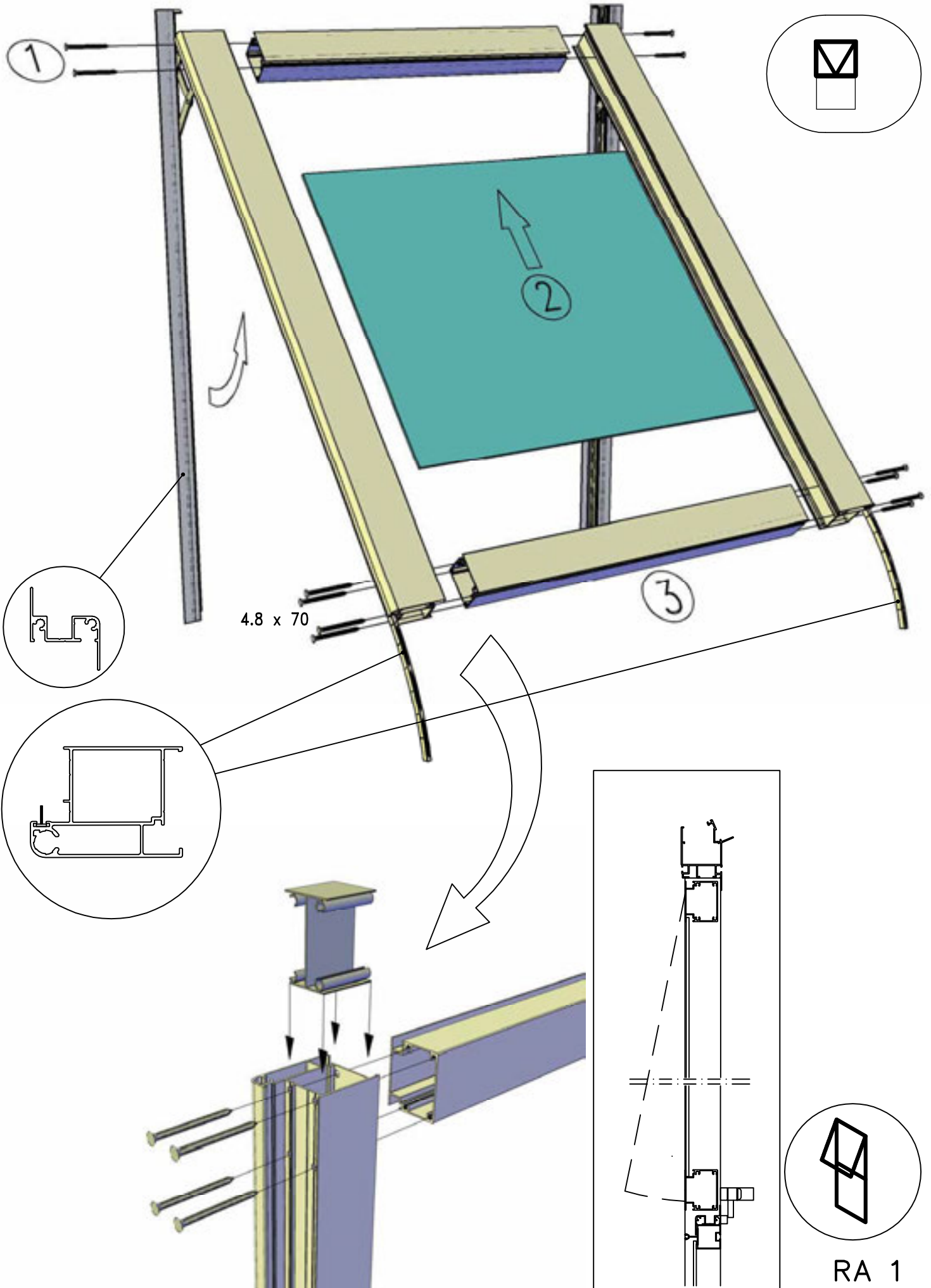

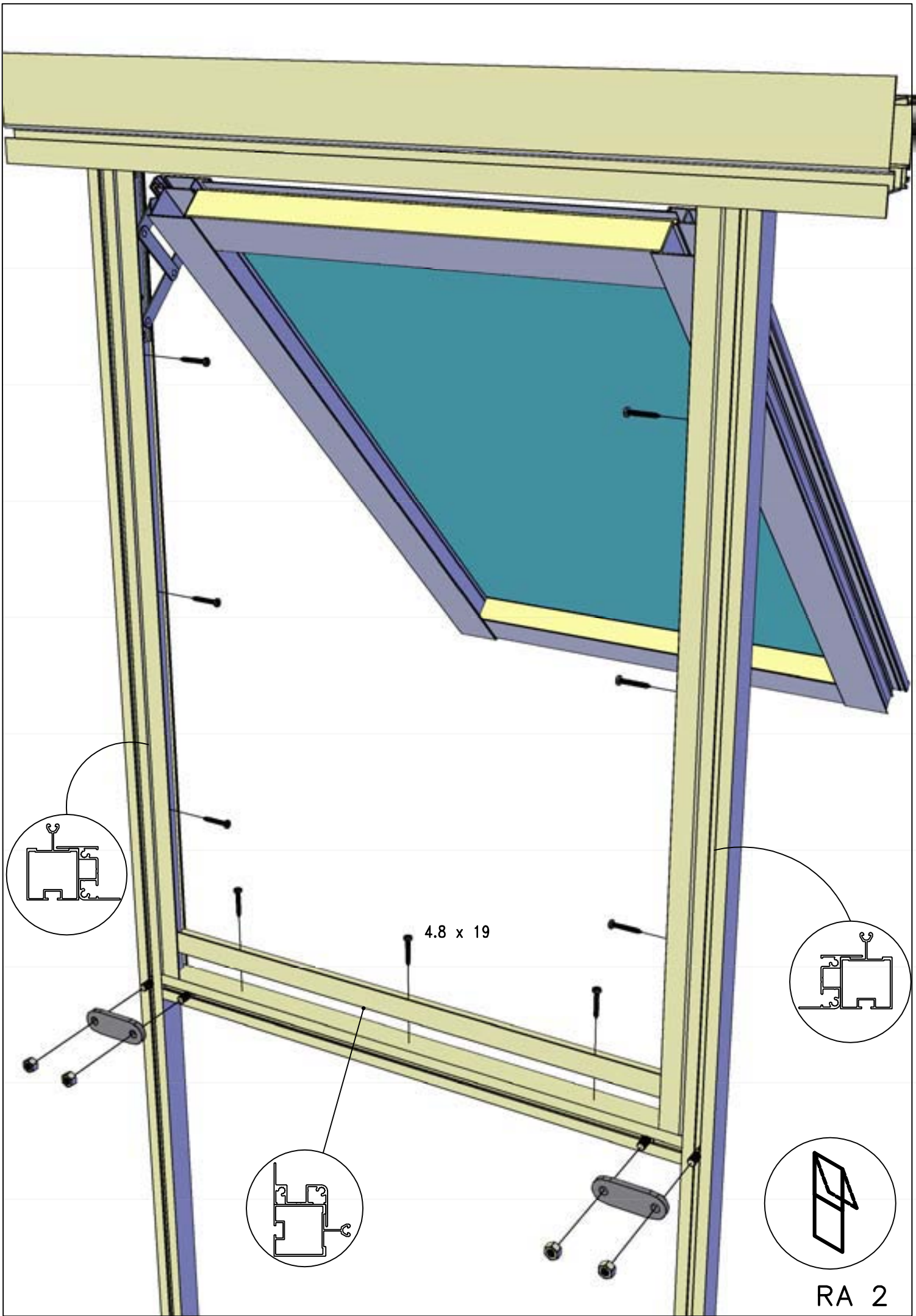

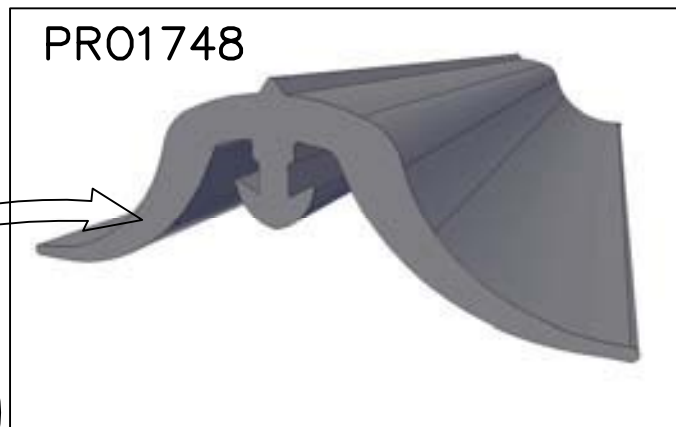
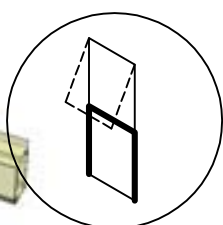
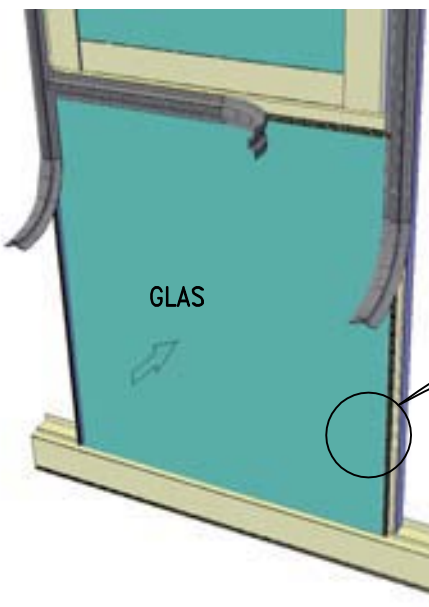
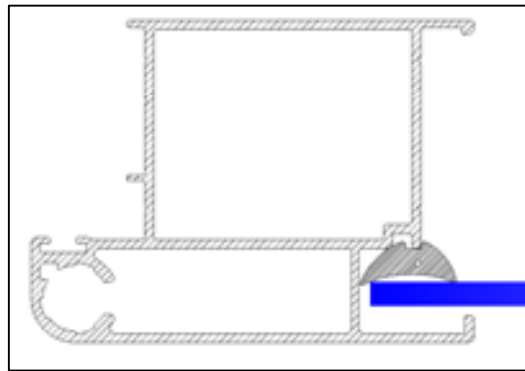
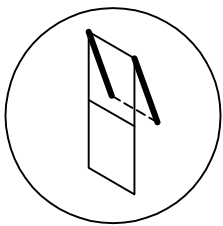
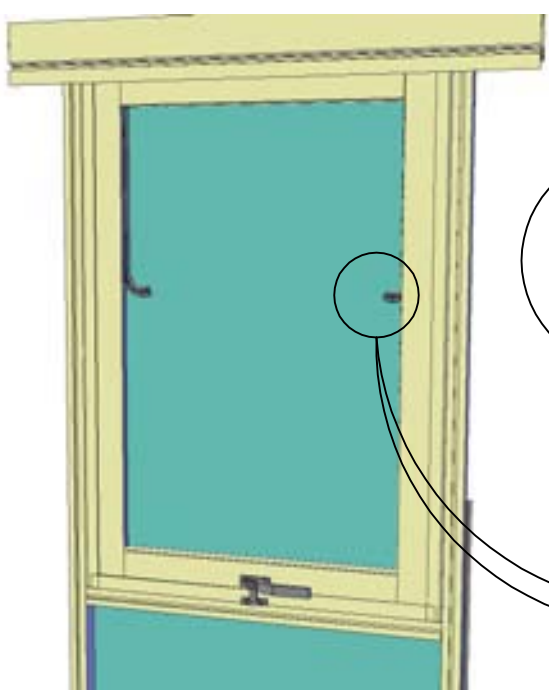
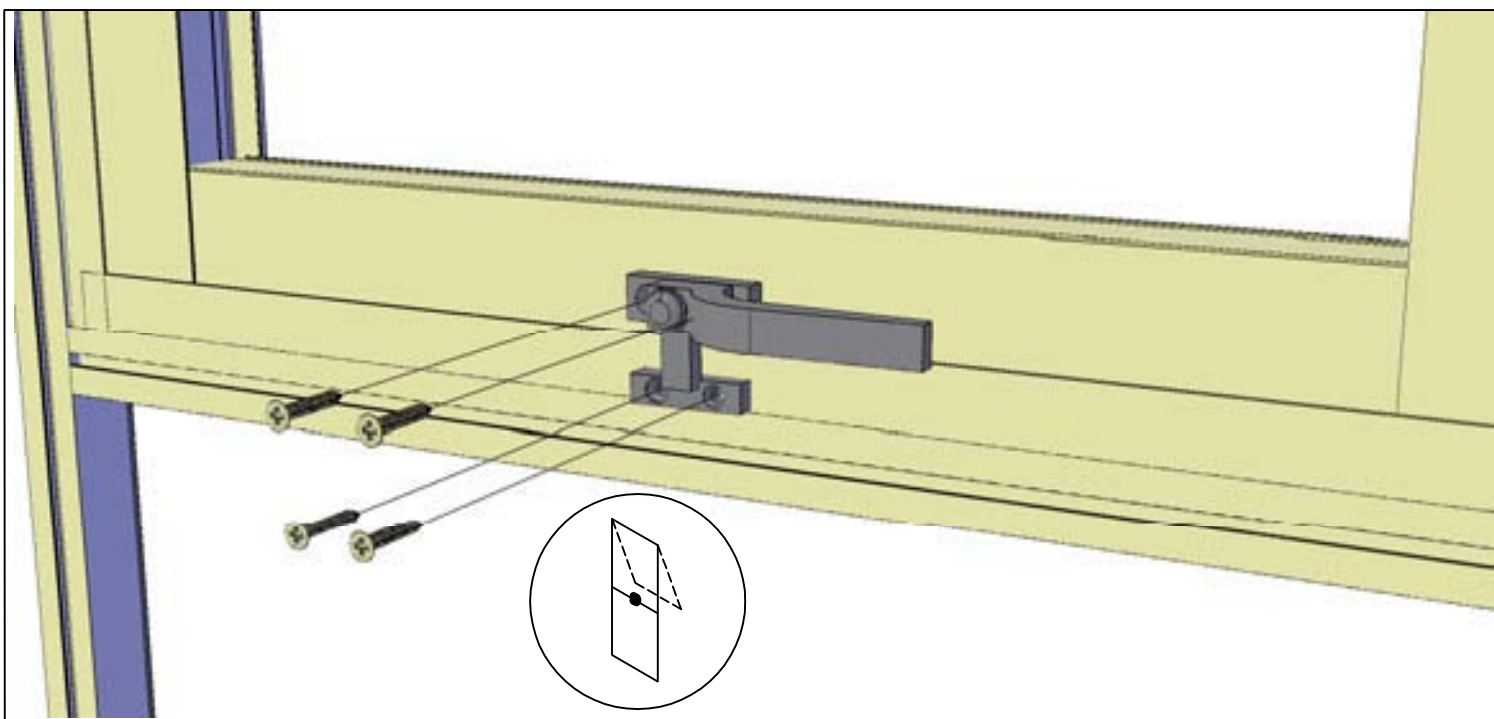

Zaibak-Bac de Culture-Kulturkübel-Seedbed-Blomsterbakke Dyrkningskasse-Såbädd-Bancale da semina

01

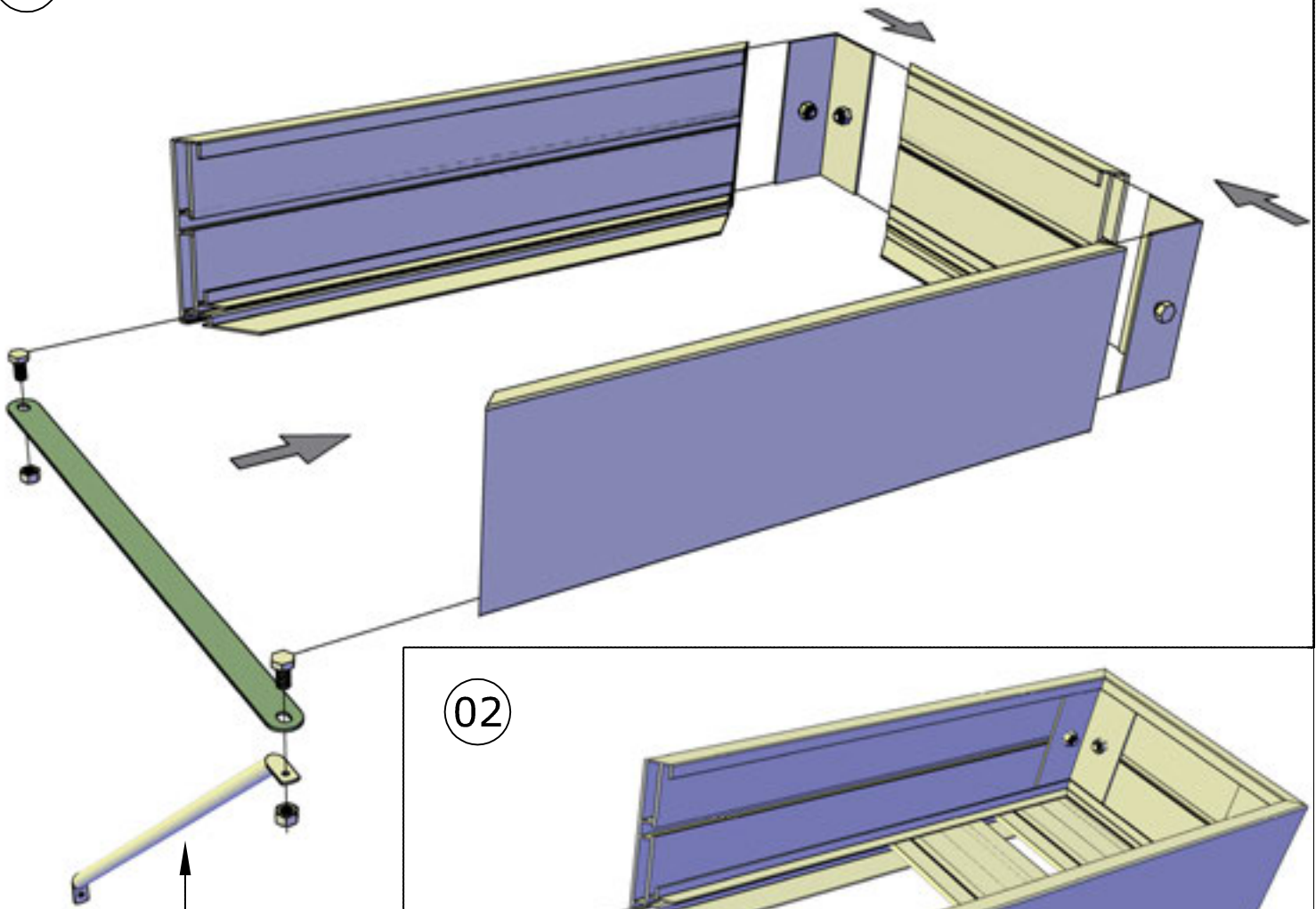

HELIOS
ARCADIA >3,5M

02

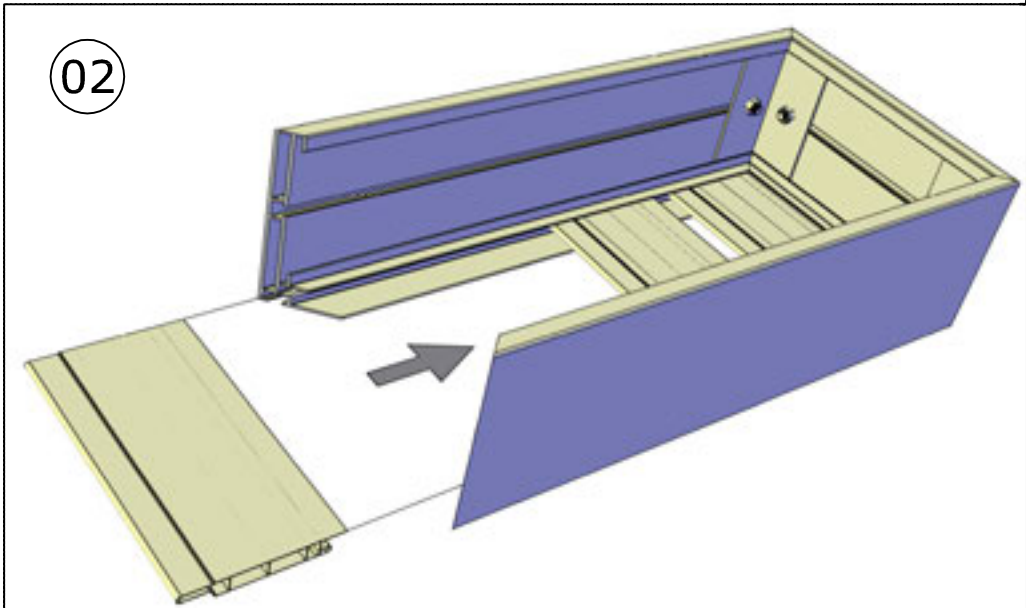

03

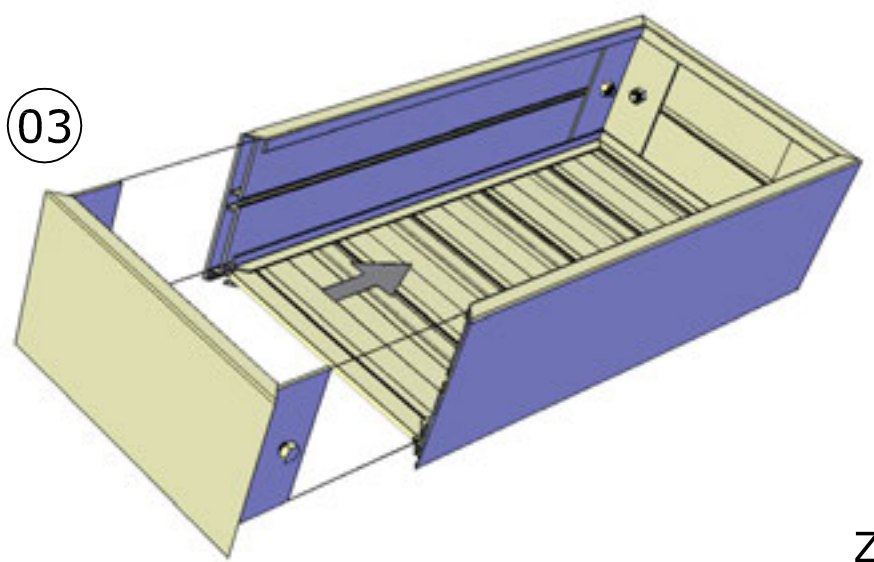

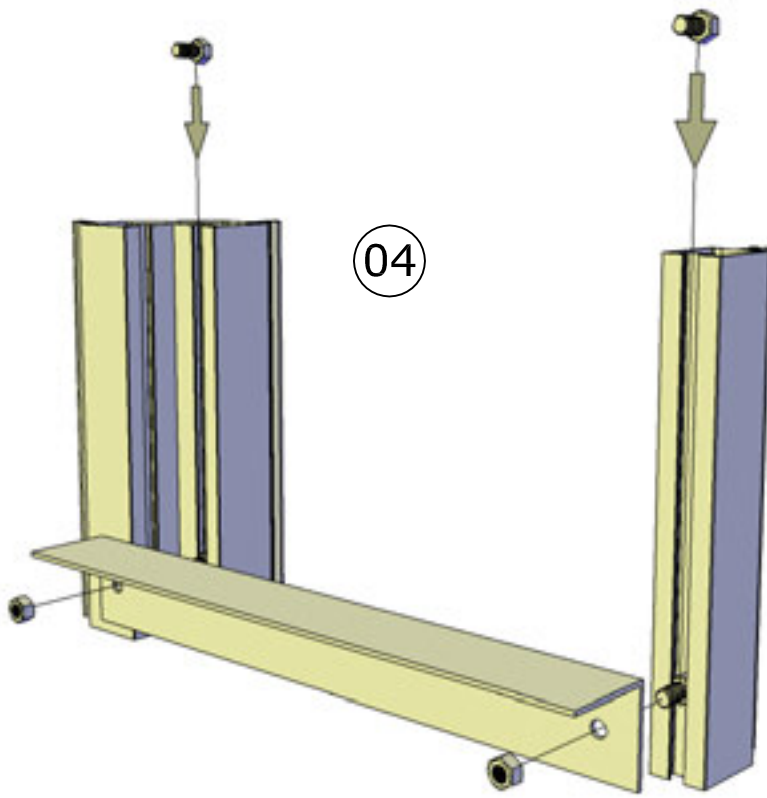

04

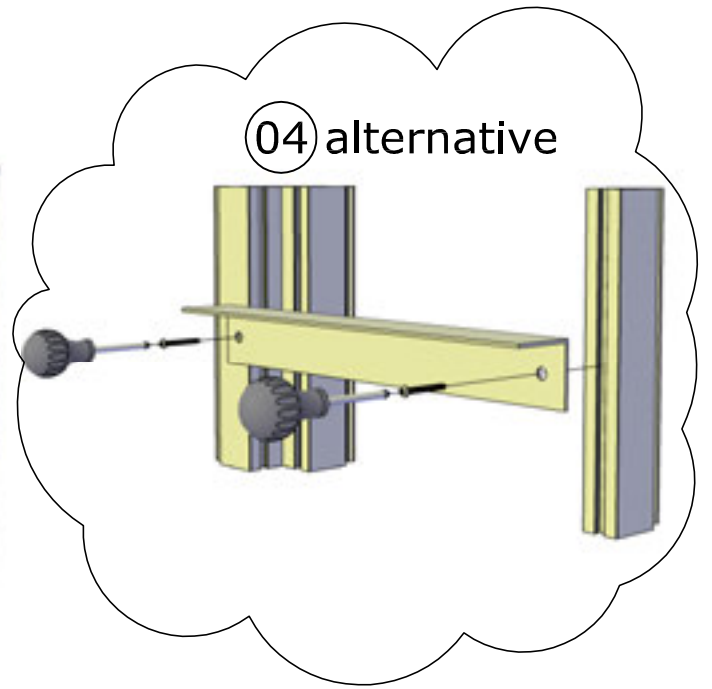

04 alternative

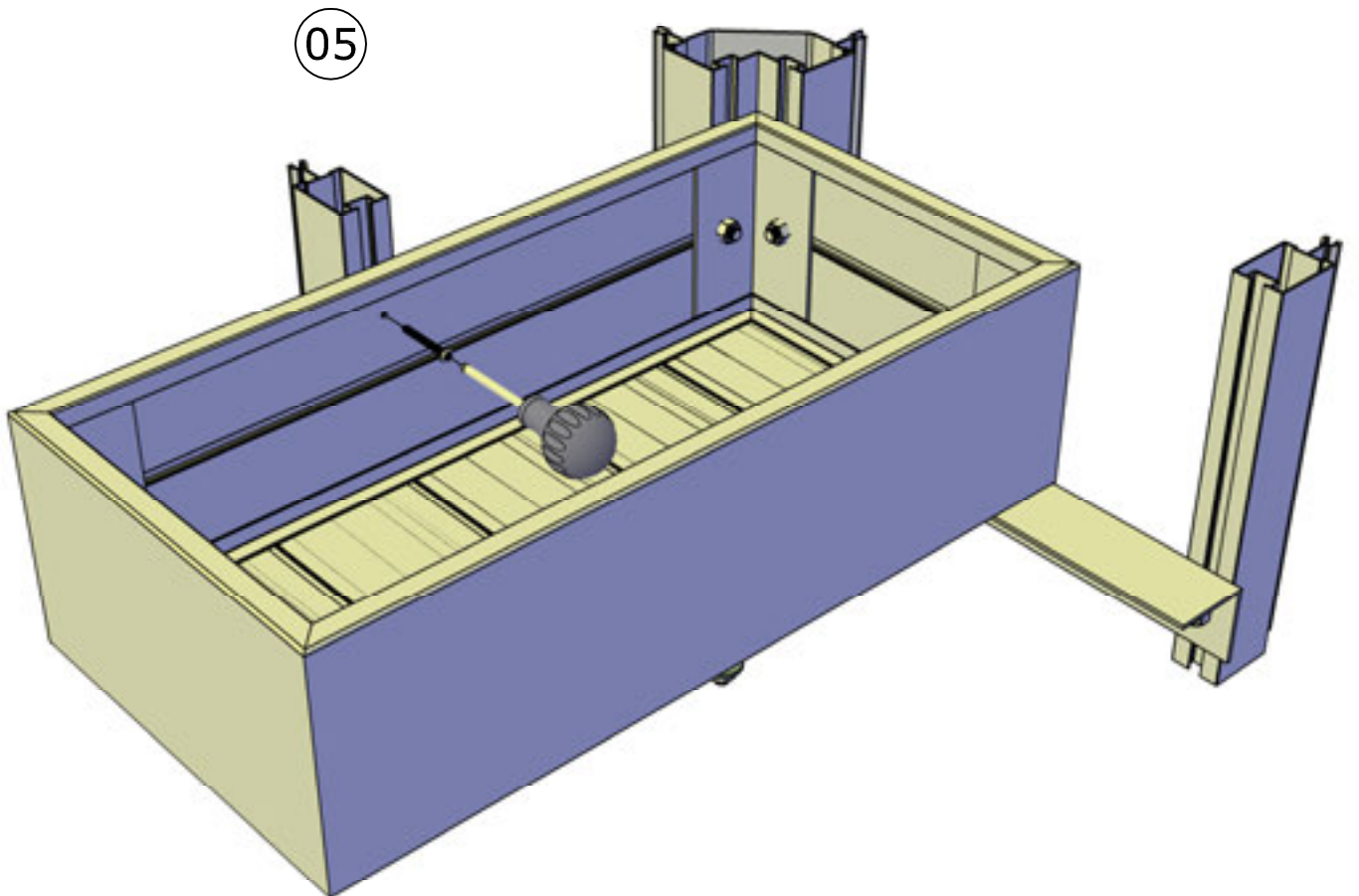

05

Schap - Etapère - Abstellbord - Shelf - Hyide - Hyller - Hyllor - Ripiano di appoggio

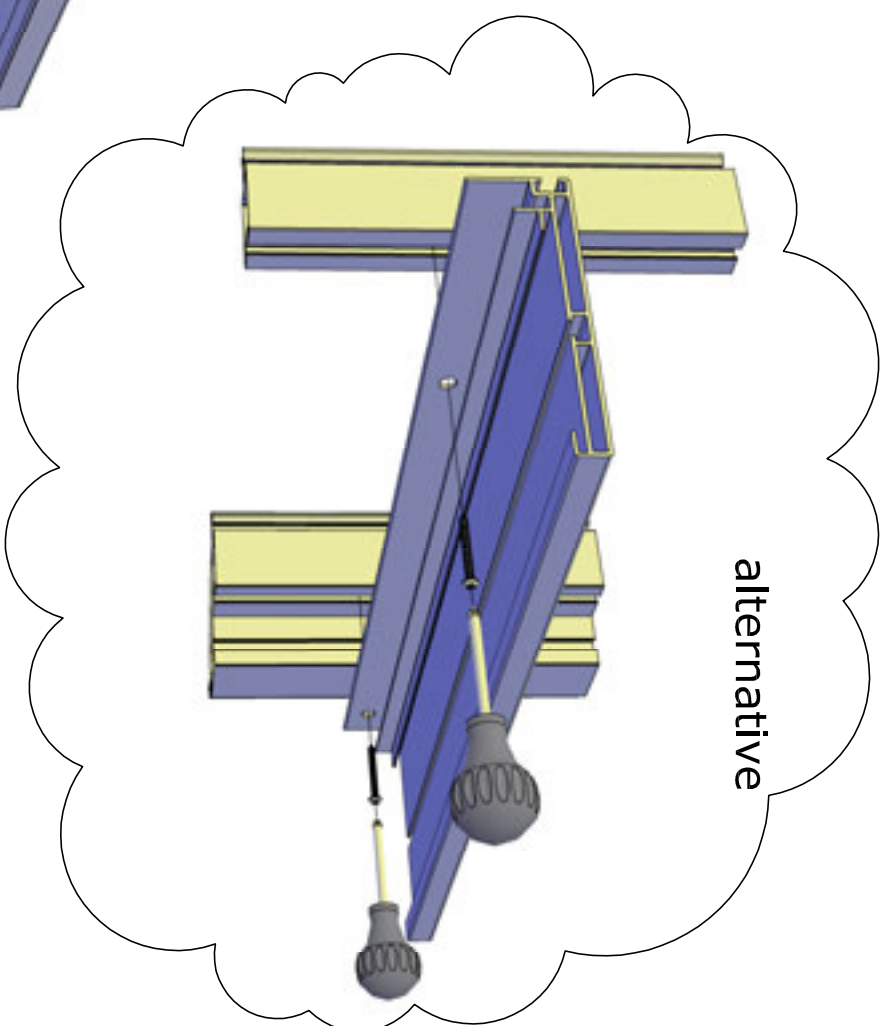
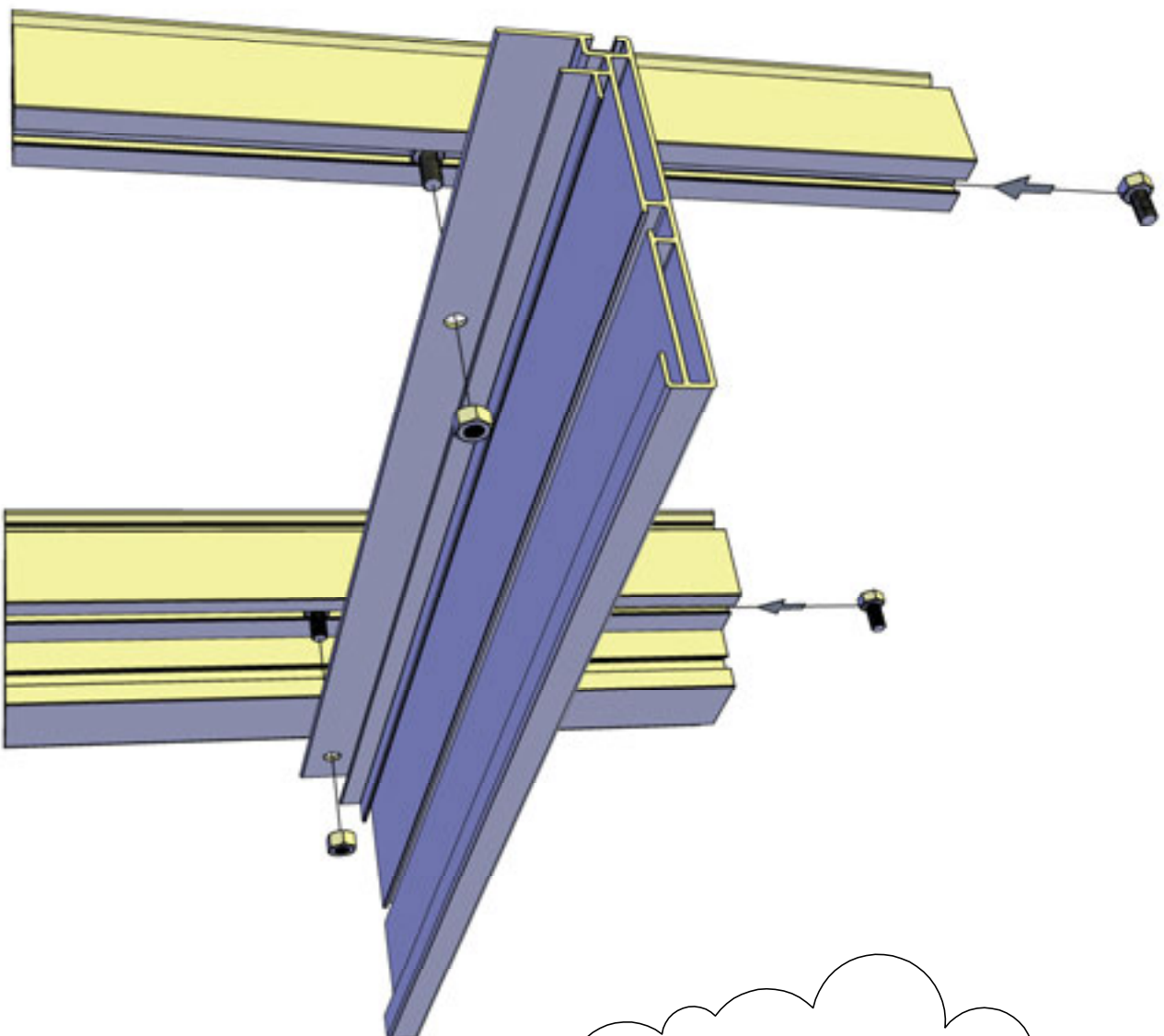

Janssens NV Mechelsesteenweg 388, B-2500 Lier Belgium
(T) +32 15 30 67 80 (W) www.janssens-alusystems.be (E) info@janssens-alusystems.be